

# COTTM 2024

## Exhibitor Manual

Venue: Hall 11, National Agriculture Exhibition Centre

Date: 16<sup>th</sup> – 18<sup>th</sup> October 2024

Dear Exhibitor,

Thank you for participating at COTTM 2024. The exhibition & conference will take place at the National Agriculture Exhibition Centre in Beijing, China from 16<sup>th</sup> – 18<sup>th</sup> October 2024. To prepare your stand and to benefit as much as possible from your participation, we herewith provide you with the exhibitor manual. We advise you to read this carefully.

The Manual is divided as follows:

- (A)** Contact Details
- (B)** Show Venue Information
- (C)** Show Schedule with Important Dates
- (D)** Show Venue, Contractors & Suppliers
- (E)** General Information and Regulations on the venue, admission, stands, exhibits management, insurance, liability
- (F)** Shell Scheme Stand Information
- (G)** Stand Construction and Management
- (H)** Health & Safety / Emergency Procedures
- (I)** Exhibit Transportation
- (J)** Order Form Checklist
- (K)** Order Forms
- (L)** Furniture Catalogue

Please make sure you return all mandatory and other relevant order forms to the respective companies before the deadlines. If you need any advice or assistance, please contact a member of the exhibition team and we will be happy to help.

We look forward to working with you over the next few months and see you in Beijing.

Best regards,  
COTTM Team

## CONTENTS

---

---

(A)	Contact Details	Page 02
(B)	Show Venue Information	Page 03
(C)	Show Schedule with Important Dates	Page 04
(D)	Show Venue, Contractors & Suppliers	Page 05 - 8
(E)	General Information and Regulations	Page 09 - 17
(F)	Shell Scheme Stand Information	Page 18 - 20
(G)	Stand Construction and Management	Page 21 - 27
(H)	Health & Safety / Emergency Procedures	Page 28 - 29
(I)	Exhibit Transportation	Page 30 - 41
(J)	Order Form Checklist	Page 42

---

## (A) CONTACT DETAILS

<b>Project Director</b>	
<b>Ms. Qinghui Qing</b> TEL: +86 (21) 6157 7024 E-mail: Qinghui.Qing@informa.com	
<b>Exhibition &amp; Sponsorship Sales</b>	
<b>Ms. Jane Carter</b> TEL: +44 (0) 20 7660 7197 E-mail: jane.carter@informa.com WeChat: Chels2807	<b>Ms. Sarah Hu</b> TEL: +86 (21) 6157 3824 E-mail: Sarah.hu@informa.com WeChat: Sarah_jinjin
<b>Marketing &amp; Visitor Promotion</b>	<b>Visa, Show guide</b>
<b>Ms. May Cui</b> TEL: +86 (21) 6157 3825 E-mail: May.cui@informa.com WeChat: 15600514589	<b>Ms. Sarah Hu</b> TEL: +86 (21) 6157 3824 E-mail: Sarah.hu@informa.com WeChat: Sarah_jinjin
<b>Exhibition Operation:</b>	
<b>Mr. Allen Wang</b> Tel: + 86 (21) 6157 3927 E-mail: Allen.Wang.CN@informa.com WeChat: Allen940301	
<b>Stand Contractor</b>	
Pico IES Group (China) Co Ltd Contact: Ms. Susan Zhang / Ms. Serena Li Tel: +86 21 6010 8786 / 6010 8774 E-mail: susan.zhang@pico.com / serena.li@pico.com	
<b>Official Freight Forwarder and Customs Broker</b>	<b>Translation and temporary staff services</b>
APT Showfreight Shanghai Co., Ltd. Beijing Branch Office Contact person: Shelly Li TEL: 86 (10) 62192131 Email: shelly.li@aptshowfreight.com	Global Tone Communication Technology Co Ltd. Contact person: Yu Lan Tel: 150-10015180 E-mail: yusulan@gtcom.com.cn  Sichuan Wanrun Culture & Media Co., Ltd. Contact person: Heleno Tel: 18513410804 E-mail: 1151225109@qq.com

## (B) SHOW VENUE INFORMATION

Venue: Hall 11, National Agriculture Exhibition Centre

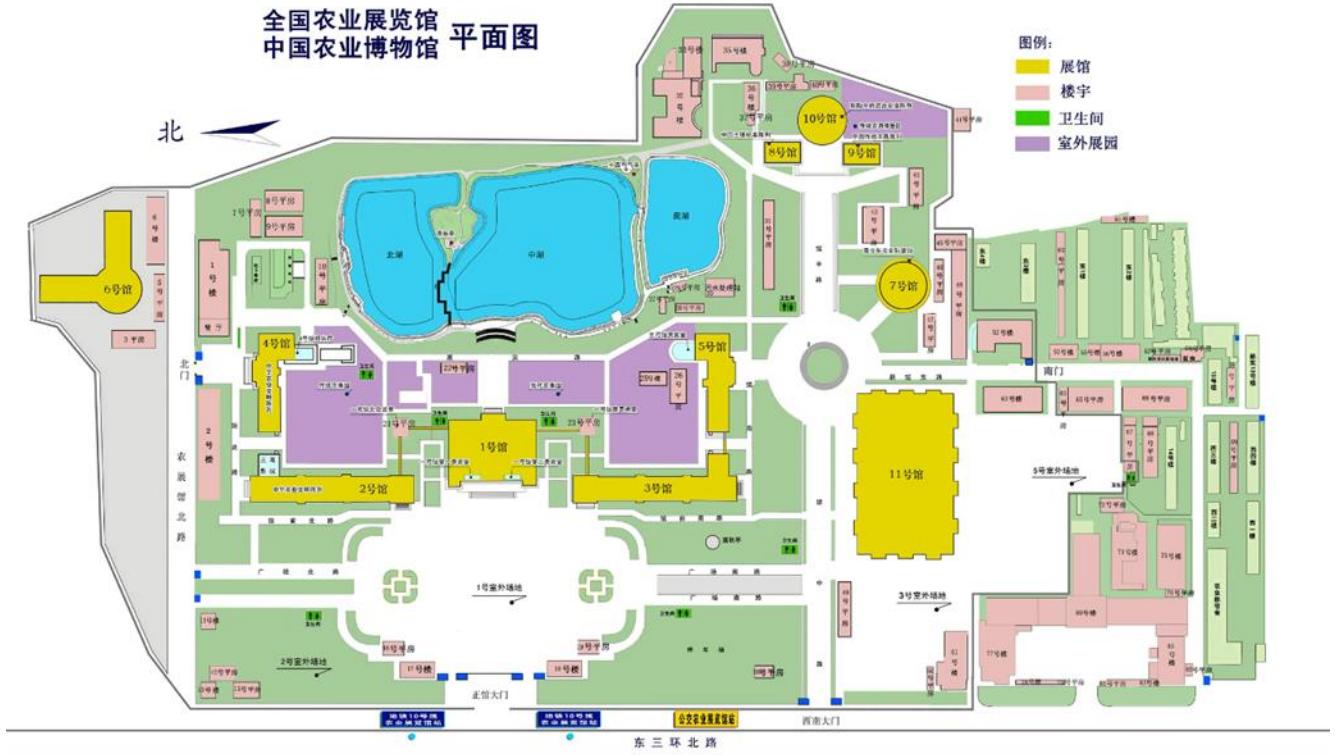

### (C) SHOW SCHEDULE WITH IMPORTANT DATES

<b>Build-up Period (Exhibitor and Contractor Move-in):</b>		
14 <sup>th</sup> October, 2024	08:30 – 17:00	
15 <sup>th</sup> October, 2024	08:30 – 20:00	
<b>Main construction work must be finished by 12:00pm on 15<sup>th</sup> October.</b>		
Contractors are required to work within these move-in periods. If contractors wish to work beyond these hours they should contact the Organiser in advance.		
<b>Exhibitor Registration:</b>		
15 <sup>th</sup> October, 2024	10:00 – 17:00	
<b>Exhibition Hours:</b>		
	<b>Exhibitor Access only</b>	<b>Exhibition Opens</b>
16 <sup>th</sup> October, 2024	09:00 - 17:00	9:30 - 17:00
17 <sup>th</sup> October, 2024	09:00 - 17:00	9:30 - 17:00
18 <sup>th</sup> October, 2024	09:00 - 16:00	9:30 - 16:00
<b>Move-Out:</b>		
18 <sup>th</sup> October, 2024	16:00 – 20:00	<b>Contractor and Forwarder access for stand break-down &amp; dismantling of electrical installations &amp; removal of heavy exhibits</b>

**(D) SHOW VENUE, CONTRACTORS & SUPPLIERS**

---

---

**D1 Exhibition Hall Specifications & Regulations**

---

**D2 Freight Forwarder**

---

**D3 Stand Contractor**

---

**D4 Temporary Staff**

---

**D5 Insurance Agency**

---

**D6 Hotel**

---

---

**D1 EXHIBITION HALL SPECIFICATIONS & REGULATIONS**

Venue: Hall 11, National Agriculture Exhibition Centre

<b>FACILITIES</b>	<b>Description</b>
FLOOR LOAD-BEARING CAPACITY	2000KG/SQM
ACCESS FOR EXHIBITS/VISITORS	14
ELECTRICITY CAPACITY	1000A
BROADCASTING SYSTEM	AVAILABLE IN HALLS AND OFFICES
WATER SUPPLY	AVAILABLE IN HALLS AND OFFICES
EMERGENCY LIGHTING	AVAILABLE IN HALLS AND OFFICES
FIRE PROTECTION	AUTOMATIC FIRE SPRINKLER SYSTEM, FIRE DETECTION & ALARM SYSTEM WITH RISER & HOSE REEL, PORTABLE FIRE EXTINGUISHERS
AIR CONDITIONING	28°C IN SUMMER, 23°C IN WINTER

---

**D2 FREIGHT FORWARDER**

**APT Showfreight Shanghai Co., Ltd. Beijing Branch Office (APT)** is the Official Freight Forwarder for **COTTM 2024** and can provide a comprehensive range of services including: customs clearance, insurance and transportation. The agreed shipping arrangements between **APT** and the individual exhibitor will ensure that exhibits and all related articles arrive at the Exhibition Centre well in advance of the exhibition date to provide for customs clearance, transportation and unpacking procedures. Please note that shipping goods to China takes time, due to the distance involved. It is far cheaper to ship items by sea, but you must allow approximately 4-6 weeks for this service. Therefore, we strongly recommend you contact APT and arrange your freight delivery as soon as possible to secure the most cost-effective price.

Overseas exhibitors or authorized agents should apply to the address listed below for full information on forwarding procedures. **APT** will issue individual Exhibition Transport Guidelines to exhibitors.

**Exhibitors are reminded that in the interests of security and efficiency, APT is EXCLUSIVELY responsible for coordinating the handling of goods and exhibition materials into and out of the Exhibition Centre.**

All road freight, airfreight and sea freight shipments must be consigned **FREIGHT PREPAID** per the Shipping Manual.

**\*\*\*\*\*Please DO NOT co-sign shipments to COTTM, or to VENUE. \*\*\*\*\***

Overseas business contact person: Shelly Li  
TEL: 86 (10) 62192131

Email: shelly.li@aptshowfreight.com

China contact person: Yu Chang

Tel: +86 15001399306

Email: jason.yu@aptshowfreight.com

---

### **D3 STAND CONTRACTOR**

**Pico IES Group (China) Co Ltd** is the official stand contractor for standard shell scheme construction and electricity supply.

Pico IES Group (China) Co Ltd

Contact: Ms. Susan Zhang / Ms. Serena Li

Tel: +86 21 6010 8786 / 6010 8774

Fax: +86 21 6010 8601

E-mail: susan.zhang@pico.com / serena.li@pico.com

---

### **D4 TEMPORARY TRANSLATOR STAFF**

Global Tone Communication Technology Co Ltd.

Contact person: Yu Lan

Tel: 15010015180

Mail: yusulan@gtcom.com.cn

Sichuan Wanrun Culture & Media Co., Ltd.

Contact person: Heleno

Tel: 18513410804

Mail: 1151225109@qq.com

---

### **D5 INSURANCE AGENCY**

Specialist

M: 1801 6358 139

E: zhanhuikefu2022@163.com

Ms. Nancy Lin

M: 1379 5447 441

E: nancy.lin@clema-rs.cn



Ms. Yolanda Duan  
M: 1302 1092 086  
E: yolanda.duan@clema-rs.cn

---

**D6 HOTEL**

COTTM has signed with China's leading online travel booking company, Trip.com. to provide booking services for COTTM 2024 exhibitors. Please use the following links or scan the QR code to access to the services you may require:

<https://www.trip.com/hotels?locale=en-XX&allianceid=3839119&sid=81970512>



## **(E) GENERAL INFORMATION AND REGULATIONS**

---

---

- |            |   |
|------------|---|
| <b>E1</b>  | <b>Activities on Exhibition Stands</b>    |
| <b>E2</b>  | <b>Animals</b>                            |
| <b>E3</b>  | <b>Audio-Visual Presentations</b>         |
| <b>E4</b>  | <b>Access to the Exhibition Hall</b>      |
| <b>E5</b>  | <b>Exhibits Move In, And Move Out</b>     |
| <b>E6</b>  | <b>Catering</b>                           |
| <b>E7</b>  | <b>Children</b>                           |
| <b>E8</b>  | <b>Delivery of Exhibits</b>               |
| <b>E9</b>  | <b>Fire Precautions</b>                   |
| <b>E10</b> | <b>Free Visitor Invitations</b>           |
| <b>E11</b> | <b>Insurance</b>                          |
| <b>E12</b> | <b>Intellectual Property Rights</b>       |
| <b>E13</b> | <b>Internet Access</b>                    |
| <b>E14</b> | <b>Medical Requirements</b>               |
| <b>E15</b> | <b>Photography / Video Shooting</b>       |
| <b>E16</b> | <b>Public Address System</b>              |
| <b>E17</b> | <b>Security</b>                           |
| <b>E18</b> | <b>Visas for China Invitation Letters</b> |
| <b>E19</b> | <b>Smoking</b>                            |
| <b>E20</b> | <b>Environmental Guidelines</b>           |
| <b>E21</b> | <b>Overtime Work</b>                      |

---

## **E1 ACTIVITIES ON EXHIBITION STANDS**

Exhibitors cannot use any area outside the boundaries of their stand for displays or promotional activities. The Organizers have the right to remove all items from common areas and / or charge for the additional space used. Failure to adhere to this guideline may result in your stand being closed.

---

## **E2 ANIMALS**

For reasons of health and safety animals are not allowed in the exhibition halls for the duration of the tenancy with the exception, of guide dogs for the blind and hearing dogs for the deaf accompanying disabled exhibitors/visitors.

During the move-in and move-out period no animals will be allowed on site if it is deemed unsafe. At all times the Organizers decision is final.

---

## **E3 AUDIO-VISUAL PRESENTATIONS**

No activity which, in the opinion of the Organizers, amounts to a nuisance or annoyance to the public or other exhibitors shall be permitted in the Exhibition. Audio-visual display equipment must be positioned, and the sound level adjusted so as not to annoy other exhibitors or visitors. The use or testing of any noise-generating equipment in any part or parts of the exhibition stand should not exceed the maximum permitted noise level of 70dB(A). The Organizers reserve the right to require any audio-visual presentation or other equipment which is, in its opinion, detrimental or offensive to be disconnected or discontinued.

---

## **E4 ACCESS TO THE EXHIBITION HALL**

No one will be permitted into the exhibition hall during build-up, show period or breakdown without an appropriate badge.

### **Exhibitor Badges**

Badges will be issued to all Exhibitors and staff manning their stands at the venue **Exhibition Registration Counters**.

Please note that Exhibitor's badges are only for staff manning stands during the exhibition days, whereas contractor's passes are given to suppliers and contractors who are assisting in decorating the

stand, building and dismantling structures during move-in and move-out days only. Exhibitors and their personnel are requested to wear their badges while in the hall for the duration of the show and contractors are to wear their passes for access to the hall during the build-up and move-out period.

### **Contractor Badges**

- The stand contractor should provide the Exhibition Liability Insurance Certificate and the Safety Commitment to Official Contractor, by 13<sup>th</sup> September 2024.
  - After the contractor pays the Damage Deposit and hall management fee on 14<sup>th</sup> or 15<sup>th</sup> October 2024. Then the badge center will issue the contract badge.
- 

### **E5 EXHIBITS MOVE IN AND MOVE OUT**

A “Transport Pass” must be obtained at the exhibition venue’s pass management office before driving vehicles into the Hall 11.

A “Transport Pass” is RMB 100/vehicle with a RMB 300 deposit. The refund of the deposit is based on the presentation of the “Transport Pass” as well as the deposit receipt after the timely completion of the loading. Any loss or damage of the “Transport Pass” will result in the deposit being forfeited.

The time limit for loading is an hour. An overtime charge will be assessed at RMB 100 for every 60 mins (minimum charge).

Once the loading is finished, vehicles should depart immediately to avoid unnecessary traffic congestion for which the deposit will be deducted.

---

### **E6 CATERING**

No outside food and beverages are allowed in the Exhibition Centre. All catering on your stand must be ordered through the catering outlets in Exhibition Center.

---

### **E7 JUVENILES**

The Fair is open to buyers and trade visitors ONLY. The Organizers and Venue Management will enforce this regulation. This includes the build-up period as well as the exhibition; if you are an overseas exhibitor travelling with your family, please note this point. Health and safety and liability regulations

always prohibit the presence of under 18 in the halls, either as a visitor or exhibitor and there will be no alternative facilities provided.

#### **E8 DELIVERY OF EXHIBITS**

Without the specific permission of the Organizers, no exhibits are allowed to be taken into the show once the Exhibition has been officially opened or be removed from the stand before the closing of the Exhibition.

#### **E9 FIRE PRECAUTIONS**

Please ensure you are familiar with the Fire and Emergency Procedures in the Health & Safety Section in this Manual.

---

#### **E10 VISITOR INVITATIONS**

All Visitors Must need a badge to enter the Exhibition Hall. We strongly encourage you as exhibitors to plan your own publicity campaign by inviting existing and potential clients to the show.

---

#### **E11 INSURANCE**

Exhibitors are responsible for taking out Exhibition liability insurance against injury to persons and property of others on their stand, along with their exhibits and merchandise moving to and from the show and during the show. Each exhibitor should have a valid and adequate insurance cover of no less than **RMB 15 million** against public liability.

Exhibitors should contact their insurance broker to cover their exhibits and exhibit materials. The Organizers will not be held responsible for any loss of or damage to, exhibits and personal items.

Please complete **Form-1** and return it to the official contractor.

**Exhibitors are reminded of their responsibility for their representatives, which also includes their contractors and sub-contractors.**

#### **Cléma Risk Solutions**

Ms. Nancy Lin

M: 1379 5447 441

E: nancy.lin@clema-rs.com

Ms. Yolanda Duan  
M: 1302 1092 086  
E: yolanda.duan@clema-rs.com

Address: Room 608, No. 1900 Tianshan Rd. Changning District, Shanghai 200051, China

It is essential that Exhibitors with Raw Space/Special Design stands check any stand contractors being considered for work have this insurance coverage, before appointing them.

---

## **E12 INTELLECTUAL PROPERTY RIGHTS**

The Organizers, **TARSUS**, have a procedure in place at fairs and exhibitions organized by the Organizers in People's Republic of China ("PRC") ("Exhibitions") to address complaints that products on display at the Exhibitions infringe on someone else's intellectual property rights. The procedure is aimed at assisting individual exhibitors to protect their intellectual property rights and to respect the intellectual property rights of others.

The rules and regulations set out in this brief are supplementary regulations in addition to the Terms & Conditions of the Standard Rules & Regulations and form part of the Exhibition Contract signed by exhibitors with the Organizers.

### Outline Procedure

1. If you would like to make a complaint involving an alleged infringement of your intellectual property rights, your complaint should be referred to the Exhibition Operations Office.
2. If you receive a complaint at your stand, you should refer the complainant to the Exhibition Operations Office.
3. Complainants must, at the time of filing their complaints with the Exhibition Operations Office, provide the following documentary evidence to substantiate their claims:
  - a) Trademark  
Original or certified copy of a valid Certificate of Registration of Trademark that is enforceable in a PRC Court, including any renewal certificates or proof of renewal.
  - b) Registered Design  
Original or certified copy of a valid Certificate of Registration of Design that is enforceable in a PRC Court, including any renewal certificates or proof of renewal.
  - c) Patent  
Patent Certificate, patent announcement documents, patent legal documents (copy of the patent register book or copy of the payment receipt the last year).

OR

d) A Court Order issued by a PRC Court against the Infringing Goods.

e) An authorization letter or power of attorney from the right owner if the complaint is filed by an agent on behalf of the intellectual property right owners.

In addition, the Complainant must submit a completed "Complaint Form" setting out the details of the complaint including: the Exhibitor's name, stand number, date, complainant's name, a brief description of the nature of the complaint and a description of the product(s), photograph(s) or product catalogue of the product(s) the subject of the complaint.

4. If the Organizers are satisfied, on the basis of the documents provided, that the Complainant's intellectual property rights are valid and the Exhibitor has a case to answer, the Organizers will notify the Exhibitor involved of the claim and require the Exhibitor to remove the product or any material in question immediately from their stand and for the remainder of the Exhibitions unless the Exhibitor can provide evidence to the satisfaction of the Organizers that he/she has the right to display the product or material in question. It should be noted that such procedure is purely an administrative procedure undertaken by the Organizers to assist the Complainant and the Exhibitor to resolve their dispute during the Exhibitions. It is not to be construed as any indication that the Exhibitor has infringed the intellectual property rights of the Complainant. The Complainant and the Exhibitor must seek independent legal advice and an appropriate order from the PRC Court if such an indication is required.

5. If a Complainant produces an Order from the PRC Court in respect of the product or material in dispute, the Organizers will require the Exhibitor to remove the product or material in question immediately from their stand and for the remainder of the Exhibitions, unless the Exhibitor can provide evidence to the satisfaction of the Organizers that the goods in question do not fall within the terms of the Order or that he/she has the right to display the product or material in question, notwithstanding the terms of the Order.

6. If the Exhibitor refuses to cooperate with the Organizers in completing the procedures outlined in paragraphs 4 and 5 above, the Organizers shall have the power, at its sole and absolute discretion, to immediately terminate the Exhibitor's right of participation in the Exhibitions in question without any refund of the participation fee already paid by the Exhibitor and to ban the Exhibitor or any parent, associate, affiliated and/or subsidiary company from any and/or all future Exhibitions of the Organizers.

7. It is expressly understood and agreed by all Complainants and Exhibitors that the Organizers, their servants and agents are not in any way liable for any intellectual property infringement during Exhibitions. While the Organizers will take reasonable steps to require Exhibitors to respect the Complainant's intellectual property rights, the Organizers cannot take a view as to whether an infringement has occurred. Complainants and Exhibitors must seek their own independent legal advice and an appropriate order from the PRC Court if their dispute cannot be resolved under the Organizer's complaint procedures.

8. Complainants agree and irrevocably undertake to indemnify the Organizers on demand against any or all claims, liabilities, losses, damages, costs (including legal fees) and expenses of any nature whatsoever incurred or suffered because of or howsoever arising out of the complaints filed by Complainants.

The Organizers expressly reserve their right to amend the rules and regulations set out in this brief from time to time.

---

#### **E13 INTERNET ACCESS**

There is no wireless internet service provided in the Center.

---

#### **E14 MEDICAL REQUIREMENTS**

Please bring with you any prescribed drugs you may need, since they may not be readily available in China.

---

#### **E15 PHOTOGRAPHY / VIDEO SHOOTING**

As per the exhibition rules & regulations, unauthorized photo/video shooting and sound recording of any stands / displays / demonstrations is not allowed, without the agreement of the exhibitors concerned.

---

#### **E16 PUBLIC ADDRESS SYSTEM**

The public address system is for use by the Organizers and Authorities only. During the exhibition only official and emergency messages will be broadcast.

#### **E17 SECURITY**



Security patrols are provided by the Organizers for the total exhibition area. Nevertheless, Exhibitors are advised that they are required to arrange their own insurance coverage and not to leave their stands unattended and take responsibility for the security of their stand display, stand merchandise and personal items during the show. Please note that most hired cabinets have common locks and should NOT be regarded as secure units. Any incidents of theft must be reported to the Organizers immediately as it will be necessary to complete a security form and report the incident to the police.

---

#### **E18 VISA FOR CHINA INVITATION LETTERS**

If you require clearance (VISA Letter of Invitation) to visit China, please contact E-mail as Jane Carter: Jane.carter@informa.com,或 Sarah Hu: Sarah.Hu@informa.com.

---

#### **E19 SMOKING**

Smoking is prohibited anywhere inside the venue.

---

#### **E20 ENVIRONMENTAL GUIDELINES**

All attendees shall act the role of protecting environment. Here are some tips helping you to participate in the exhibition more environmentally friendly, by reducing amount and re-using.

1. Make reasonable plan for quantity of distribution. Please do not print and transport materials more than the quantity you need.
  2. Use environmentally or recycled materials as many as possible. Make reasonable plan of your booth design and construction. Reduce wooden materials as many as you can, but use assembled materials instead so that you can reuse them. Don't use plastic bags to distribute promotional materials. Give up advertisements and signage in PVC but use cotton or paper instead.
  3. Use no toxic, volatile paint and glue for construction. And use CFL or LED light as many as you can. And so is recycle carpet.
  4. Reduce using packaging materials and paper boxes to the minimal quantity.
-

## **E21 OVERTIME WORK**

During the pre-show (move-in) period, exhibitors and contractors are permitted to construct and decorate their stands during official hours. Any request for overtime work is allowed with paid overtime and prior notice.

Overtime Work detail:

- **17:00—24:00 RMB 7800/hr/stand**
- **24:00—8:00 RMB10400/hr/stand**

## (F) SHELL SCHEME STAND INFORMATION

### STANDARD SHELL STAND (NOT TO SCALE)

(Number of panels depends on dimensions of stand, 1m per panel)

**6sqm**

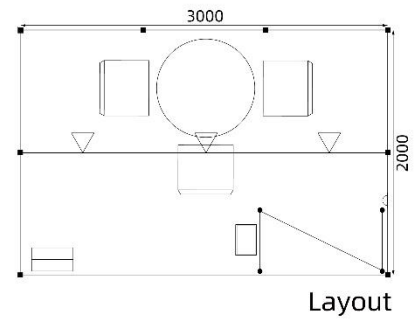

Sample:



Size:2000mmLx400mmH



This design is copyright of Pico IS Group Limited. Construction is subject to site conditions and specifications. This drawing is subject to modification without notice to the client.

PROJECT  
COTM 2024

CLIENT / ORGANISER

CITY / VENUE

SHOW PERIOD

PERSON IN CHARGE  
Roy

DESIGNER  
Zhou Peng

**9sqm**



Panel Size:950mmLx2340mmH

Panel Size:950mmLx640mmH

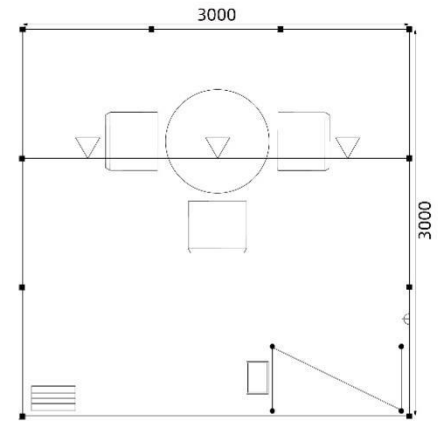

Layout

Sample:

-  问询台  
Info Counter
-  葫芦椅  
Meeting Chair
-  废纸篓  
Wastepaper Basket
-  白圆桌  
Round table
-  30W LED 轨道射灯  
30W LED Track Light
-  插座  
Power Socket
-  立式资料架  
Magazine holder



Size:2000mmLx400mmH



This design is copyright of Pico ES Group Limited. It is intended for reference only and is subject to pre-approval. This drawing is subject to modification for all kinds of other purposes.

PROJECT  
COTTM 2024

CLIENT / ORGANISER

CITY / VENUE

SHOW PERIOD

PERSON-IN-CHARGE  
Roy

DESIGNER  
Zhou Peng

**18sqm**

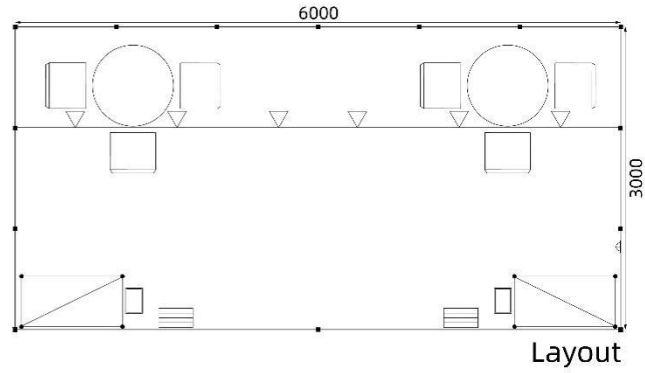
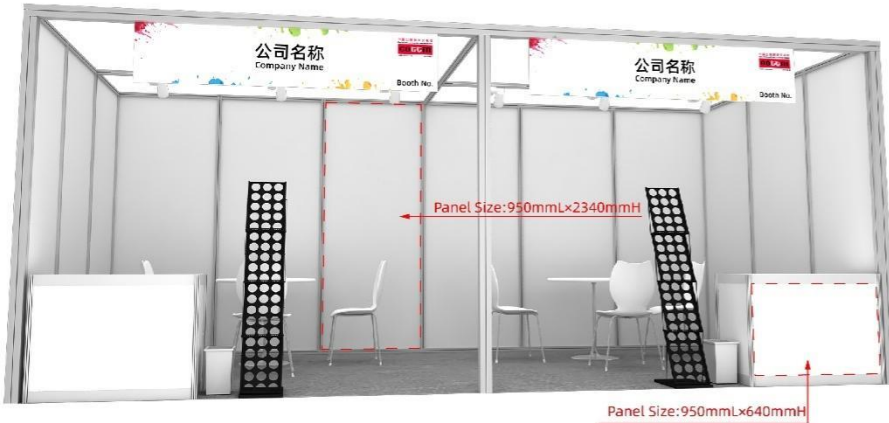

**Sample:**

-  问询台  
Info Counter
-  30W LED 轨道射灯  
30W LED Track Light
-  葫芦椅  
Meeting Chair
-  插座  
Power Socket
-  废纸篓  
Wastepaper Basket
-  立式资料架  
Magazine holder
-  白圆桌  
Round table



Size:2000mmLx400mmH



This design is copyright of Pico ICS Group Limited. Unauthorised use in part or in whole is subject to prosecution. This Drawing is subject to modification without notice for any purpose.

PROJECT  
COTTM 2024

CLIENT / ORGANISER

CITY / VENUE

SHOW PERIOD

PERSON-IN-CHARGE  
Roy

DESIGNER  
Zhou Peng

\*Please be reminded that the above items cannot be interchanged with other items. If exhibitors do not require any of the items, no refund will be given.

## **(G) STAND CONSTRUCTION AND MANAGEMENT**

---

---

<b>G1</b>	Fire Prevention Regulations
<b>G2</b>	Contractor Insurance
<b>G3</b>	Stand Building Height
<b>G4</b>	Special Design (Raw Space) Exhibitors
<b>G5</b>	Electrical Installations
<b>G6</b>	Stand Design Drawings
<b>G7</b>	Stand Design Drawings Approval Procedure
<b>G8</b>	Cleaning & Garbage Disposal
<b>G9</b>	Contractor Damage & Performance Deposit
<b>G10</b>	Air Compressors / Pressurized Containers
<b>G11</b>	Nailing / Drilling / Painting
<b>G12</b>	Personal Protective Equipment (PPE)
<b>G13</b>	Rear Surfaces of Stands
<b>G14</b>	Storage
<b>G15</b>	Move-Out Instructions

When an exhibitor appoints an outside contractor to build their stand or an exhibitor builds their stand by themselves (if an exhibitor is building their own stand, they are considered as an outside contractor during the move-in/out period), both the exhibitor and contractor must fully understand following information and regulations. Exhibitors and contractors are expected to comply with any building regulations laid down by the Organizer.

### **G1 Fire Prevention Regulations**

The Stand Contractors, exhibitors and other sub-licensees and their contractors, sub-contractors, agents and employees shall follow all local, city and state regulations covering fire and safety.

- On-site contractors shall be fully responsible for construction quality. They shall mitigate the possibility of accidents such as the collapse of stands, injury or damage of exhibiting facilities caused by faulty design or construction.
- **All the carpet used in the booth must be flame retardant. The venue will require the contractor to prove the flame-retardant license and check all the carpet before move-in. The carpet will not be allowed to take into the venue if the contractor can't approve the flame-retardant license.**
- Wooden structural booth must be fireproof treatment; light boxes and other heating equipment must be set up air vents. It is strictly prohibited private wires.
- Heating equipment are not allowed to be used during set-up. Welding equipment or other smoke substances is prohibited. Paint in the exhibition hall is not allowed.
- Fire alarms, extinguishers, fire hydrants, fire hoses, emergency exits, etc. shall always be kept clear.

---

### **G2 CONTRACTOR INSURANCE**

Each Individual Stand Contractor **must have** valid insurance cover for minimum RMB 15 million against public liability for the entire move-in/out and show period. Individual Stand Contractors are required to present the certificate to the Organizers prior move-in. The Organizers reserve the right to refuse access to Stand Contractors that fail to do so.

---

### **G3 STAND BUILDING HEIGHT**

Standard height of shell scheme is 2.5m. **The maximum height of raw space booth is 4m.**

---

#### **G4 SPECIAL DESIGN (RAW SPACE) EXHIBITORS**

Special Design exhibitors are responsible for appointing their own contractors for stand design and construction. It is the raw space exhibitor's responsibility to carpet and furnish their licensed space. All carpets and floor coverings can be affixed with double-sided tape. The use of paint or glue on the floor of the exhibition hall is strictly forbidden. Should any damage occur, it is the exhibitors/appointed contractor's responsibility to meet the costs involved.

All exposed rear surfaces of designs and structures must be decorated unless facing the actual walls of the Exhibition Hall.

The order forms for electricity and furniture are included in this Manual. All exhibitors with raw space must complete and submit **the form by the deadline**.

Please also note the insurance requirements listed in this section.

The exhibitor (or their appointed contractor) is also responsible for the dismantling of the stand at the end of the show and removing all material used. Failure to do so will result in the automatic forfeit of the total deposit. In addition, the contractor involved will not be permitted to work on future events.

Where a "Special Design" stand is located adjacent to "Shell Scheme" stand, the wall of the "Shell Scheme" stand is considered rented by that exhibitor and may not be utilized by the "Special Design" stand. Capping is not allowed in the booth. In violation of this regulation, 2,000 RMB will be deducted, and the illegal roof will be removed.

---

#### **G5 ELECTRICAL INSTALLATIONS**

1. The installation of electric circuits and electric equipment must be conducted by the persons with a valid electrician operation certificate, and illegal operation is strictly prohibited. All the operation must comply with the relevant national electric specifications. In case of trouble, the construction unit will bear all the responsibility and the resulting consequences.
2. The distribution boxes for booths must be placed in the cable trench or exhibition unit in the pavilion (and the cable trench cover should not be opened arbitrarily). It is strictly forbidden to put the distribution boxes in a distinct position in the corridor, passage and booth. The electric circuits laid in a hidden place should be protected in a metal tube or flame-retardant PVC pipe, and safe distance should be ensured between lamps and inflammables (more than 0.5 m).
3. Electric circuits must be equipped with a shunt switch and protected in trunking in case of extending across the corridor.
4. It is strictly prohibited to place inflammables, a water dispenser and the like around the distribution box.
5. It is strictly forbidden to use without authorization the fixed electricity box facilities in the pavilion. All the electric circuit capacity should be allocated evenly, and the circuits should be laid overhead



- or by taking effective protection measures; load equipment should have a good grounding device.
6. Wires to be laid should be sheathed wires and must be connected by using dedicated connectors. No flexible wires should be adopted except use as fixture wires.
  7. Illumination lamps should be kept away from inflammables by more than 50 cm. Rectifiers for fluorescent lamps, high-pressure mercury-vapor lamps and other illumination lamps should not be installed on inflammables or combustibles.
  8. In case of installing enclosed light boxes, vents for sufficient heat dissipation should be provided. The electric circuits and light boxes and other important positions in wooden exhibition units must be treated by more than three-coat fireproof paint.
  9. Easily hot electric equipment and high-temperature lamps can be used only after approval; no inflammables, combustibles or other objects should be placed around high-temperature lamps (within one meter). Outdoor electric lighting equipment should be moisture-proof, and moisture-proof and other safety measures should be implemented.
  10. It is strictly prohibited to use surface iodine tungsten lamps or halogen tungsten lamps and neon lamps in the pavilion.
  11. All the units and people using the pavilion facilities should strictly abide by the above regulations, for any violations, the facility management side
- 

## **G6 STAND DESIGN DRAWINGS**

### **Special Design (Raw Space) Stands**

When Exhibitors sign an Exhibition Space Contract, they agree to abide by all the Rules & Regulations and those set out in this Manual, and to ensure that their Contractors abide by them in order to avoid any dispute, you must submit the layout of your stand to the Organizers, for review and approval. All design proposals must conform to all statutory requirements and those set out in this Manual and must include the following:

- Plan view, showing clearly all dimensions, booth number, walling and major exhibits.
- Elevation views showing clearly all dimensions, graphics, etc.
- Structural calculations / drawings proving structural stability, weight loadings, etc.
- Details of materials and fire protection.
- The display wall at the edge of the stand must not be completely blocked when facing the exhibitor on the opposite side of the gangway, and half of the length must be reserved .If the length of the display wall on the edge of the booth exceeds 50% of the side length in this direction due to design or other reasons, the display wall must be indented 0.5 meters to the booth to build, and the side of the display wall facing the gangway needs to be decorated by auxiliary pictures, lighting and other technical means. The design plan must get approval in advance by the organizer and PICO.

All drawings should be on a recognized scale not less than 1:50. All plans are to be submitted to PICO online system(<http://ordering.picoies.cn/COTTM.aspx>) before **13<sup>th</sup> September 2024**

The design of stands must be such that they can be erected and safely dismantled within move-in/out time available.

Contractors should include a Risk Assessment in the design proposal.

**G7 STAND DESIGN DRAWINGS APPROVAL PROCEDURE**

Please find below stand approval procedures for your easy reference. Please note that contractor badges will only be made available before move-in upon the stand design drawings approval procedures being completed.

	<b>Action</b>	<b>Quick Reminder</b>
Step 1	The Organizers initiate first stage stand design vetting on or before <b>13<sup>th</sup> September, 2024</b>	Stand drawing submission deadline: <b>13<sup>th</sup> September, 2024</b>
Step 2	Drawings may be forwarded to the Safety Officer for further vetting, along with your returned <b><u>Form 1 Form 2</u></b>	<b><u>Form 1 &amp; Form2</u></b> submission deadline: <b>13<sup>th</sup> September, 2024</b>
Step 3	<ol style="list-style-type: none"> <li>1. Contractors should take the initiative to submit before <b>13<sup>th</sup> September 2024</b></li> <li>2. Contractor Performance Bond to Official Stand Contractor</li> <li>3. Contractor Insurance Policy to the Organizers</li> </ol>	Performance Bond + Contractor Insurance deadline: <b>13<sup>th</sup> September 2024</b>
Step 4	If no further revisions are required by the Safety Officer and provided that the Contractor has settled the contractor performance bond and present the contractor insurance policy, the Organizers will send out details on collection of contractor badges.	

**G8 CLEANING & GARBAGE DISPOSAL**

The Organizers will arrange for general cleaning of the exhibition hall and standard/deluxe/showcase stands, prior to the opening of the exhibition and daily thereafter. For raw space/upgrade stands, exhibitors must arrange daily cleaning of their stand – please arrange with your stand contractor or order this service from PICO. All disposal of waste materials etc. during the move-in period is the responsibility of the individual stand contractors concerned. Disposal of contractor’s waste materials by the Organizers will result in the contractor’s deposit being forfeited.

In the case of ‘ready stand’ exhibitors bring in shelving and stand fittings, these cannot be left behind at the close of the show. **It is the exhibitor’s responsibility to dismantle all stand fixtures built or**

**brought in by themselves and remove all waste materials from the Centre at the end of the show.** Failure to comply will result in a charge for the labor and trucking required to dispose of the material.

---

#### **G9 CONTRACTOR DAMAGE & PERFORMANCE DEPOSIT**

A contractor damage & performance deposit must be paid to the Official Stand Contractor on behalf of the Organizers against damages and rubbish disposal along with breaches of guideline on safe working practices and stand building. (Please refer to [Form 1a](#)). Access to the site will not be permitted until this deposit has been paid.

---

#### **G10 AIR COMPRESSORS / PRESSURIZED CONTAINERS**

No Exhibitor may use their own air compressor or pressurized containers within the exhibition hall.

---

#### **G11 NAILING / DRILLING / PAINTING**

No nailing, drilling, painting or fixtures of any kind are allowed on the partitions, floor, ceiling or any hall structure. Exhibitors will be liable for any damage to their stands, fixtures & fittings and the exhibition venue.

---

#### **G12 PERSONAL PROTECTIVE EQUIPMENT (PPE)**

Correct footwear protecting against nails, debris etc. are required for exhibitors/contractors working in the exhibition centre during build-up and dismantling.  
Reflective safety vests are mandatory for all personnel including exhibitors during stand construction period.

Safety helmets are required for working at height. Contractors are required to have any other PPE which are needed for their work, such as gloves, goggles, masks, earplugs.

Please refer to Health & Safety Section for full details.

---

**G13 REAR SURFACES OF STANDS**

Contractors must have any exposed stand surfaces neatly finished unless the surface is facing the outer wall of the exhibition centre. The Organizers reserve the right to order modification of any exposed surface and the contractor shall be responsible for the cost. Exhibitors/contractors are not allowed to put advertising, logos, signs etc on any rear surface of their stand when this faces or is adjacent to other exhibitor's stand. **Strictly no covering by cloth is allowed on any exposed stand surfaces.**

---

**G14 STORAGE**

Fire regulations prohibit storage of cartons and literature behind stands, and these will be disposed of without prior notice. The Official Freight Forwarder provides a storage service for empty cartons, wooden crates, etc.

---

**G15 MOVE-OUT INSTRUCTIONS**

Neither exhibitors nor appointed contractors are permitted to dismantle any part of their exhibit before the official closing time of 16:00 on 18<sup>th</sup> October 2024. Freight entrances will only be opened after the show has been officially closed. Packing, bringing in carton boxes, trolleys etc. to the show is NOT permitted before 16:00 under any circumstances. The Organizers strongly request that all exhibitors comply with and respect this regulation so as not to prejudice either the sales activities of other exhibitors or the safety of attendees in the show.

## **(H) HEALTH & SAFETY / EMERGENCIES**

---

---

---

**H1** Health & Safety

---

**H2** Emergency Procedures

---

---

## **H1 HEALTH & SAFETY**

Please refer to the <Guide of Health & Safety> attached.

---

## **H2 EMERGENCY PROCEDURES**

### **Useful Telephone Numbers**

Ambulance: 120

Police: 110

Fire: 119

Use these numbers ONLY when the Emergency Number is busy or is not answered within six (6) rings.

### **Emergency Exits**

All emergency exits are marked with green exit signage.

### **Medical**

In the case of an accident/injury, please take following measures:

- (1) Call the Emergency Number immediately, giving the exact location and details of the accident/injury.
- (2) If possible, help treat/comfort the injured party until qualified help arrives.

### **Fires**

The venue is equipped with a fire sprinkler and alarm system. Portable hand-held fire extinguishers are also located at each gate inside the halls. If you detect fire or smoke:

- (1) Activate the nearest fire alarm if possible and safe to do so.
- (2) Call the Emergency Number immediately, giving the exact location and details of the fire.
- (3) Leave the exhibition hall immediately by the nearest exit.
- (4) Close doors behind you.

If you hear a fire alarm, please remain calm and alert, and prepare at once to leave Shanghai World Expo Exhibition & Convention Centre.

### **Evacuation**

If you hear a fire alarm evacuation announcement or instruction:

1. Leave the Shanghai World Expo Exhibition & Convention Centre by the nearest safe exit.
2. Follow announcements over the public address system or instructions by Shanghai World Expo Exhibition & Convention Centre staff and/or fire/police officials.
3. Once outside the Shanghai World Expo Exhibition & Convention Centre, stay clear of the venue; do not return until it is declared safe to do so by Shanghai World Expo Exhibition & Convention Centre management, or fire/police officials.

## (I) EXHIBIT TRANSPORTATION

### TIME SCHEDULE 时间表

<u>LOE (list of exhibits) Deadline to APT by Sea Freight</u> 海运展品清单提交 APT 截止日期	.....	5 days before arrival
<u>LOE (list of exhibits) Deadline to APT by Air Freight</u> 空运展品清单提交 APT 截止日期	.....	3 days before arrival
<u>Exhibits Arrival Deadline by Sea Freight to Xingang Seaport</u> 展品海运发运至天津新港	.....	LCL: 17 September. 2024 FCL: 24 September. 2024
<u>Exhibits Arrival Deadline by Air Freight to Beijing PEK Airport</u> 展品空运发运至北京首都国际机场	.....	8 October. 2024

### DOCUMENT REQUIREMENT 所需文件

- 1 original Bill of Lading or 1 copy of Express Bill of Lading or 1 copy of Master Air Waybill and 1 copy of House Air Waybill  
海运提单正本一份 / 电放海运提单副本一份 / 空运总运单及分运单副本各一份
- 1 copy of List of Exhibits (abbr. as LOE, the legitimate document accepted by Customs, refer to the appendix) or ATA Carnet with POA / 1 copy of Insurance Policy (if insured)  
展品清单一份（海关审核的法定文件，详见附件）或者 ATA 单证册及授权书和保险单一份（如有）

**\*\* If any machine or display model, please provide correct model or serial number on LOE or ATA. Photo of each item declared on ATA Carnet should be attached with ATA general list page.**

请注意：如有任何设备或演示模型等，请务必在展品清单或 ATA 单证册上提供正确的型号。ATA 上所列明的所有品名都需要提供照片作为附件由 ATA 签发商会盖章并附在 ATA 总清单后。

### CONSIGNMENT INSTRUCTION 发运指示

All cargoes must be consigned "**Freight Prepaid**" to the following consignee, otherwise a 10% outlay commission will be imposed on all "Freight Collect" consignments. Each AIR shipments should be under ONE MASTER Air Waybill with ONE back to back HOUSE Air Waybill (not for each exhibitor) and the HAWB must be manifested by airline. Additional charges will be incurred for wrong consignee details.

Effective 1st June 2018, additional shipper and consignee information will be required for electronic reporting of cargo to Chinese Customs IT system, as per the General Administration of Customs People's Republic of China (GACC) Decree No. 56.

The new mandatory data requirements below apply equally to MAWB/HAWB and must be provided in FWB/FHL Cargo-IMP messages sent to airlines & shipping lines, as well as on the paper AWB and HAWB Consolidation manifest. The new data should be in the OCI field of the IATA Cargo-IMP FWB/FHL messages, and the following formats apply to message versions up to and including FWB/16 and FHL/4.

	Information	Format
1	Trader Identification Code for Consignee	OCI/CN/CNE/T/Enterprise Code Type#
2	Trader Identification Code for Shipper	OCI/CN/SHP/T/Enterprise Code Type#
5	Specified Contact Person's Name for Consignee:	OCI/CN/CNE/CP/Name
6	Specified Contact's Phone for Consignee:	OCI/CN/CNE/CT/Phone#
7	Specified Contact Person's Name for Shipper:	OCI/CN/SHP/CP/Name
8	Specified Contact's Phone for Shipper:	OCI/CN/SHP/CT/Phone#

Note: IATA will define 2 new codes: "CP" - Contact Person and "CT" - Contact Telephone Number, in Code list 1.100, i.e. Customs, Security and Regulatory Control Information Identifiers. These 2 codes should be added to your Cargo IT systems.

所有展品必须以“**运费预付**”发运并必须按下列要求显示收货人。若展品以“**运费到付**”发运，我司将收取运费百分之十的垫付附加费。每票空运均须出具一份总运单及一份背靠背分运单（不要每家展商出一份分运单）并且分运单须录入航空公司舱单。若因收货人资料错误而产生额外费用，我司将另外收取。

根据中国海关于 2018 年 6 月 1 日起实施的 2017/56 号公告，所有在中国进口及出口的海运及空运都必须按照规定的新增发货人及收货人信息及格式在启运前提交给航空公司及船公司录入 IATA Cargo-IMP FWB/FHL 舱单系统并发送至中国海关。本次展会的具体发货人及收货人信息及格式如下：

#### **Seafreight to Xingang Seaport (海运)**

##### **Shipper on B/L:**

Shipper's company name  
Shipper's address, Two-letter ISO Country code  
CT: (Phone number)  
CP: (shipper contact person)  
T: Enterprise code type+XXX (enterprise register code in shipper's country)

##### **Consignee on B/L:**

APT Showfreight Shanghai Co., Ltd. Beijing Branch office  
Room 802D, Block B Cyber Tower, NO. 2  
Zhongguancun South Street,  
Haidian District, Beijing, 100086, CN  
CT: 86 13811121431  
CP: Shelly Li  
T: USCI+91110108693276084U

##### **Notify Party on B/L (for temporary import):**

Same as consignee  
(Remark: If shipment under ATA Carnet, please also show: ATA Carnet No.: XXX)

##### **Description of Goods on B/L:**

XXX (Remark: DO NOT show simple description as 'exhibition goods', please show the main highest value item inside shipment, for example: Wire Bonder)

#### **Airfreight to Beijing PEK Airport (空运)**

##### **Shipper on both Master AWB & House AWB:**

Shipper's company name  
Shipper's address, Two-letter ISO Country code  
CT: (Phone number)  
CP: (shipper contact person)  
T: Enterprise code type+XXX (enterprise register code in shipper's country)

##### **Consignee on both Master AWB & House AWB :**

BO YUE JIN CHENG INTERNATIONAL LOGISTICS (BEIJING) CO.,LTD.  
USCI No.: 9111010566155529XQ  
Room 312, Tower 2, GuoZun YingDi Center Xiao Yun Road No. 28,  
Chao Yang Dist, Beijing,100125  
CT: Vida Wei [Tel:+86-10-65259272](tel:+86-10-65259272)

##### **Notify Party on both Master AWB & House AWB :**

APT Showfreight Shanghai Co., Ltd. Beijing Branch office  
CT: 86 13811121431  
CP: Shelly Li  
T: USCI+91110108693276084U  
(Remark: If shipment under ATA Carnet, please also show: ATA Carnet No.: XXX)

##### **Nature of Goods on Master AWB:**

Consolidation as per cargo manifest  
XXX (Remark: DO NOT show simple description as 'exhibition goods', please show the main highest value item inside shipment, for example: Wire Bonder)

##### **Nature of Goods on House AWB:**

XXX (Remark: DO NOT show simple description as 'exhibition goods', only show main highest value item inside shipment, for example: Wire Bonder)

**Please note that if only MAWB is issued, the shipment may not be distributed to our assigned warehouse right after the shipment arriving Beijing airport. Therefore, a HAWB which is manifested by airline for the whole shipment must be issued in addition so as to avoid any extra terminal and/or storage charges levied.**

**请注意**如果货物只有总空运单，这会导致货物无法在到达新机场后直接送至我们的指定仓库，而且会大大增加机场的操作费用以及仓储费用。所以请在发货时，除了总空运单，也一并出一份有效的分运单（针对整票货即可），以免产生不必要的额外费用。

#### **TEMPORARY IMPORTATION 临时进口**



The Chinese Authorities permit exhibits to be imported into China on temporary import basis on approved trade shows. Temporary import is only allowed for 1 month from the date of entry and must be re-exported unless duties and taxes are paid in the event of conversion to permanent import. Extension of temporary import is allowed subject to Customs' approval.

**ATA Carnet is accepted for temporary import in China, but ONLY for purpose as 'Exhibition & Fairs'. Customs Bond Fee will be levied for temporary import shipment without ATA Carnet.**

**All exhibition goods under temporary import are under customs control. Exhibitors should not allow their exhibits to be taken away from the fairground without prior agreement with the customs through APT Showfreight, otherwise exhibitors will get severe punishment by Chinese customs.**

中国海关允许展品以“临时进口货品”名义进入中国，除得到海关延期批准，一般展品从抵达新起计算最多可存放一个月。期满后展品必须回运或安排完税进口。

中国海关接受 ATA 国际公约，但仅限用途为“展览品”。如果货物没有 ATA 单证册，将收取海关保证金。

展品在展馆内由中华人民共和国海关监管，因此应遵守中国海关的相关法律及法规。未征得海关同意，任何人不得将展品遗弃，出售或搬离展馆，否则海关将依法追究该展商的法律 responsibility。

### **PERMANENT IMPORTATION 永久进口**

For permanent importation of any exhibits after show closing, the buyer in China (with valid import document) shall be acted as the actual consignee. Exhibitor is required to provide APT Showfreight the actual buyer's information as well as the party who will bear the duties / taxes.

**Please contact us in advance / before shipping if any permanent importation of exhibits is required. We shall check and advice on each individual case.**

如果展品在展会结束后必须留于中国，中国的买家（持有有效的进口文件）必须作为通关中的实际收货人。展商必须告知 APT 有关实际买家的相关信息以及税项的付款人。

请预先在发货前与我们联络，我们会查询后按个别案例提供方案。

### **EARLY / LATE ARRIVALS 早到 / 晚到附加费**

An early arrival surcharge will be applicable if the shipment arrives before the stipulated deadlines and will bill exhibitor as per outlay plus 10% reimbursement fee.

A late arrival surcharge, 30% based on basic handling rate, will be applicable if the shipment arrives after the stipulated deadline.

In the event of late arrivals, APT Showfreight will make all reasonable efforts to ensure delivery before the show opens; however, no guarantee can be given. The surcharge will apply regardless of delivery date to the show site. APT Showfreight also reserves the right to reject handling any cargo that arrives at the seaport / airport only 7 days prior to the show open date. All additional charges incurred due to the late arrivals shall be borne by the exhibitors.

如展品于指定日期之前到达，所有产生的早到附加费，我司将实报实销并加收百分之十垫付费。

如展品于指定日期之后到达，我司将收取基本运输费之百分之三十(30%)的晚到附加费。

对于晚到货，我司会尽全力在展览会开幕之前将展品运至展台，但是不能给予任何承诺。即使不能如期送货至展台，我司亦需收取晚到附加费。安普特物流有限公司保留拒绝操作在展览开幕前 7 天内到达新港口/机场的晚到展品的权利。所有因晚到产生的附加费用由展商承担。

### **CASE MARKINGS 包装唛头**

For easy identification of exhibits, all packages must be marked as follows:  
为了方便识别，所有货物外包装上必须印上如下唛头

**COTTM 2024**

C/O APT Showfreight Shanghai Co., Ltd Beijing Branch Office

Name of Exhibitor : \_\_\_\_\_  
Stand Number : \_\_\_\_\_  
Case Number : \_\_\_\_\_  
Gross Weight/Net Weight : \_\_\_\_\_  
Dimensions : \_\_\_\_\_

### **RESTRICTIONS 对宣传资料之限制**

All exhibitors are advised that all promotional materials to be imported or giveaways during the exhibition must not indicate or deem to indicate that Tibet or Taiwan is a Country.

任何宣传资料中若有提到“西藏”或“台湾”之处，展商应避免使用任何使人误会西藏或台湾为国家的文字。

### **PRINTED / PUBLICITY MATERIALS RESTRICTIONS 印刷品 / 宣传资料之限制**

All exhibitors are advised that all promotional materials to be imported or giveaways during the exhibition must not indicate or deem to indicate that Taiwan or Tibet is a Country such as 'ROC'.

All book / magazine with ISBN / ISSN code can't be imported under the show but through a book trader agent instead, which will cost additional 12% on CIF value, min. USD 480.00/shipment.

**Films/ slides/ video tapes/ CDs, VCDs, DVDs/ USB disk with data or content, map and globe are not allowed to display, distribute & consume during the show due to import license restriction, so please DO NOT send any above items with shipment. APT will not take any responsibility of the shipment detained/delayed due to lack of import license.**

**In addition, exhibitors are advised that brochures, giveaways and souvenirs are subject to import duties as assessed by the Chinese Customs which must be payable on entry.**

任何宣传资料中若有提到“台湾”或“西藏”之处，展商应避免使用任何使人误会台湾或西藏为国家的文字。

所有含 ISBN 或 ISSN 编码的图书/杂志，无法以展会的名义进口，必须通过外文图书进出口公司做进口，这将产生额外的贸易费用，为 CIF 价值的 12%，最低收费美元 480.00/票。

请不要发运任何录像带、幻灯片、光盘以及有内容的U盘和地图以及地球仪等，尽管其只是用于展览目的，因为在中国这些物品需要特殊的进口批文/许可证，并且这些物品在展会期间都不允许展示、派发或消耗。若展商缺少进口批文/许可证导致货物无法清关，安普特不承担任何责任。

此外，展商需要为有关消耗的资料、赠品或纪念品缴付进口关税，税额由海关估定。

### **HAND-CARRY EXHIBITS 手提物品**

Exhibitors are strongly advised not to hand-carry goods for this exhibition as it could be detained by the Chinese Customs at the airport. Once detained, please note the **detained shipment can't be imported as exhibition goods** because the list of exhibits of detained goods were not submitted in advance to the customs system at least one month before show.

我们强力建议展商不要手提展品进入中国，因有可能导致货物被机场海关扣留。如发生扣货，请注意无法通过展览品方式再进行进口清关，因为被扣物品的展品清单未提前至少一个月提交给海关系统做备案。

### **CONTROLLED ITEMS IN CHINA 中国受管制的物品**

In case the shipment contains any controlled items by the Chinese Government, we strongly recommend that the list of exhibits should be e-mailed or faxed to APT Showfreight for checking prior to the shipment departure from the country of origin.

If required, APT Showfreight will apply necessary license/ permit on behalf of the exhibitors, but under no circumstances that APT Showfreight can guarantee such license will be granted.

**The importation of below commodities is under Customs strict control even for exhibition purpose and subject to special permit in China:**

- Foodstuff, Beverage

- All tableware / kitchenware such as (paper, glass) cup, mug, tissue/wipe & bowl etc.,
- Watches, toys
- Cosmetics / Skin care items
- Any items / materials with Endangered Species
- Animal, plant
- Art articles, Antiques, Jewelry and etc.,
- Solid wood or plywood full set of furniture. All stand building material such as wooden or plywood or MDF floor / panel and etc., or furniture component /accessory
- All electric products such as mobile charger, portable battery charger/bank, lamp, wire, cable, plug and etc.
- Glass or plastic products such as glass panel for stand building material
- Chemical products such as glue, paint and etc.,
- Medical products such as Medicine, First-aid kit and etc.

**Without Chinese Customs' approval, these items can't be imported, distributed/ tasted/ sold and/or consumed during the exhibition.**

If exhibitors need to ship any controlled items to China, exhibitors are required to submit to APT Showfreight the following documents / information for application of import permit to China at least **60 (Sixty) days** prior to the shipment departure from the country of origin:

1. Catalogue / Brochure of commodities
2. Export Permit Issued by the Products' Originating Country/ Place
3. Certificate of origin and/or Health Certificate (if required)
4. Commercial Invoice and Packing List / List of Exhibits

Relevant guidelines and permit application fee in China for controlled items will be quoted upon request.

为了避免因展品中含有受中国政府管制的物品而导致被扣留，我们强烈建议展商在从所在国发运展品前将展品清单/商业发票和装箱单以电邮或传真至我可以备提前检查确认。

如必要，我司可协助展商代理申请必须的进口许可证, 但任何情况下我司都无法保证许可申请可获批准。

以下商品受中国海关严格控制，即使作为展览会用途，也必须提供有关许可证：

- 食品、饮料
- 所有餐具 / 厨房用具，如：（纸，玻璃）杯子，纸巾，碗等物品
- 手表、玩具
- 化妆品 / 护肤品
- 含濒危物种材质物品
- 动物、植物
- 艺术品、古董、珠宝等货物
- 实木或夹板成套家具、所有搭建材料（包括但不限于：实木或夹板或中密度板制地板、展板、展墙或家具的部件和零件）
- 所有电子产品，如：手机充电器、充电宝、灯、电线、电缆、插座等
- 玻璃和塑料制品，如搭建用的玻璃板
- 化学物品，如胶水、油漆等
- 药物，如药片、急救箱等

如未得到准许及认可，此类物品将不能进口，不允许在展会派发/品尝/售卖或消耗。

如展商需要把任何受管制的物品运往中国，展商须在货物发运日 **60 天**之前向我司提交如下单据/信息：

- a. 产品目录/商品的小册子
- b. 产品原产地/国签发的出口许可证
- c. 原产地证书以及健康证明书（如需）
- d. 商业发票和正表的装箱单 / 展品清单

有关手续费及许可证申请费将另行报价。

## **COURIER SERVICE 快递服务**

We do not recommend sending it via courier service (DHL, FedEx, UPS) as the cargo might be detained by customs, unless the shipment is very small (**under 20kgs total weight**) and low value (**under USD100 total value**). Otherwise, air freight is a better choice.

Once courier detained, please note the **detained shipment can't be imported as exhibition goods** because the list of exhibits of detained goods were not submitted in advance to the customs system at least one month before show. Please contact with us before sent out shipment by courier.

If exhibitor insist to send by courier service (there is a risk that the cargo might be detained and can't be delivered in time which is beyond our control), please send it to our contact as follows:

APT Showfreight Shanghai Co., Ltd Beijing Branch Office  
Room 802D, Block B Cyber Tower, NO. 2 Zhongguancun South Street,  
Haidian District, Beijing, 100086, CN  
Tel: 0086 10 6219 2131  
Contact: Ms. Shelly Li

Please let us have air waybill copy once available. Please also note that even shipment is not detained by customs, handling charges from free arrival our office upto your booth will still be occurred @ **CNY1000.00 /shipment +duty/tax (as per outlay+10% handling fee)**. But if shipment is detained by customs, please note the shipment can't be cleared by temporary import under the exhibition.

There is courier fee of sending original shipping documents (like OBL, ATA) at **CNY400.00 /consignment**.

我们不建议使用快递服务（例如 DHL, FedEx, UPS），因货物有可能会被海关扣留，除非是非常小（总重低于 20 公斤）且价值极低（总价低于美元 100）的宣传资料等无商业价值的物品。空运是更好的选择。

**如发生扣货，请注意无法通过展览品方式再进行进口清关**，因为被扣物品的展品清单未提前至少一个月提交给海关系统做备案。请在发货之前与我们联系。

如展商还是执意使用快递服务，请自行承担货物被扣且无法准时送至展台的风险，货物可寄至以下地址：

上海安普特物流有限公司北京分公司  
北京市海淀区中关村南大街 2 号数码大厦 B 座 802D 室  
电话：+86-10-62192131  
联系人：李潇潇女士

货物发出请立即提供运单。请注意即使货物未被海关扣留，我司仍要收取送至展台的操作费用人民币 **1000.00 /shipment (税金实报实销+10%垫付佣金)**。如快件被海关扣留，将无法按照展览品清关。

快递正本运输文件（如正本提单或 ATA 单证册等）将收取快递费人民币 **400.00** 每票。

## **HEAVY AND OVERSIZE EXHIBITS 超重和超大展品**

If exhibitors have heavy and oversize exhibits, you must be on-site early to direct the operation of uncrating and positioning. If crane or forklift is required for installation of equipment, please send your requirement to us as early as possible so that we could arrange contracting such equipment in advance. A quotation will be given after receiving your enquiry.

如果展商有超重和超限展品，务必尽早到现场来进行就位操作。如需要叉车或吊机来帮助安置设备的话，请务必尽早把要求通知给我们，以便于我们可以提前安排。在接到展商的查询后我方会提出报价。

## **PACKING OF EXHIBITS 展品包装**

Exhibitors shall be responsible for the consequences of improper packing

### **A. Protection against Damage and Rain**

As the exhibits are repeatedly loaded and unloaded during transportation, shocking/bumping will sometimes be inevitable. Moreover, exhibits will be placed outdoors many times, including open-air storage at the exhibition centre before and after the exhibition. Therefore, exhibitors must take necessary precautions against damage and rain, since we cannot assume any responsibility for the damage, especially when the return exhibits are to be packed with used-packing materials (the case as

well as aluminium foil, plastic covers, etc., very often would have been damaged already during unpacking).

#### B. The Case

The case must be strong enough to avoid damage during transportation as well as unpacking, and in particular, be suitable for repacking and for sale for return movement after the exhibition. Packing in cartons is not considered suitable for repeated handling, especially for valuable or delicate equipment.

参展商要对包装不妥善造成的后果承担责任。

#### A. 避免损坏和雨侵

由于展品在运输中反复被装卸，震动和撞击是不可避免的。此外，展品被多次置于室外，包括展览前后在展览中心露天的放置，所以展商必须提前注意抵制损坏和雨侵。我们不承担任何损毁责任，尤其是当回程展品可能被已经使用过的包装材料重新包装的时候（有铝箔、塑料等包装情况下，很多时候在取出过程中已被损坏）。

#### B. 包装箱

包装箱必须要坚实到足以避免在运输和开箱时候的损坏，尤其是于展后的回程重装和销售，特别对于贵重和精密设备来说，硬纸盒包装并不适用于重复运输。

### **MOVE-IN DAYS 进馆**

Exhibits will be transferred to the exhibition venue during the move-in days. Representatives of APT Showfreight will be available to help the exhibitors with the move-in logistics including unpacking and storage of empties as applicable. However, a responsible representative of the exhibitor must be available on-site during the move-in period for supervision. In some circumstances, however, the customs at the ports or fair site may inspect the case without your presence.

一般展会于进馆期间送到展场，我们会协助展商拆箱并将展品就位和暂存空箱于展览场地(如场地许可)。在布展期间，请参展商务必在现场指导操作。有些情况下，港口或者展场的海关会在展商不在时审查货品。

### **MOVE-OUT DAYS 出馆**

Prior to the move-out days, exhibitors will be given a 'Return Shipping Instructions' to fill in based on the List of Exhibits given at time of entry of goods into China. Exhibitors are required to advise APT Showfreight if the goods will be re-exported, sold or disposed, as applicable.

During move-out days, representatives of APT Showfreight will be on-site to help exhibitors with return of empty cases, repacking, re-export, etc. as applicable. In order to ensure the closing of the exhibition can be operated smoothly, those exhibitors having heavy and oversized exhibits may be required to repack their exhibits on the next day. Our on-site operational staff will inform exhibitors the exact arrangements. Similarly, during exhibition closing, exhibitors must also supervise the dismantling and repacking of exhibits, especially for delicate or heavy equipment. When used-packing materials repack exhibits, the packing is regarded as no longer suitable to protect the equipment against damage/moisture compared with the original. Exhibitors shall therefor bear the responsibility for the consequences arising therefrom.

In the event of non-compliance of return instructions, all goods left at the exhibition venue shall be subject to disposal by the Chinese Customs and all charges relating to the disposal including duties and taxes if any, shall be borne by the exhibitor.

Exhibitors must pay special attention to the following Customs' regulations:

- Items other than those declared exhibits (e.g. personal effects, souvenir bought in China) are not allowed to be returned together with exhibits.
- Violations of these regulations will result in confiscation and heavy fines imposed by the Customs.
- **Battery, powder, liquid and gel are controlled items by airline. If exhibitors can't provide certificate for safe transport of chemical goods, please take out above items before re-pack.**
- As the airlines implement strict security rules and will ask for magnetism detection & protection for many sensitive items by air transportation including electric equipment, computer, speaker and etc., we will bill magnetism inspection fee if the detection and protection is incurred.

在展览闭幕前，我司会派发一份“回运指示”给各展商，展商需根据原有的展品清单向我司阐明展品的处理方式，如回运、消耗或散发等，以便我们在展览结束后安排展品的回运。

在展览会闭幕的当天，我们会将空包装箱送还各展台并协助展商包装。为了确保展会闭幕的顺利进行，持有超重或者超限展品的展商可能要在隔天完成展品的重装。我们的现场操作人员会通知展商确切的安排。展览会闭幕期间，参展商需现场督导我们进行展品的拆卸和重装，尤其是对大型或者精密设备。当用已使用过的材料重新包装展品时，很难确保设备不受损坏和潮气影响。参展商由此须自行承担责任。

如未收到展商回运指示，我们会将遗留于展场的展品交由海关处理，所有费用如销毁费及关税等由展商承担。

参展商需特别注意以下海关规则：

- 除了已申报的内容，其他货品如个人物品或在中国境内购买的纪念品，不能够随展品一同回运。
- 违反以上规则的货品将会被充公或从重处罚。
- **电池、粉末、液体和凝胶都属于航空公司管制物品，若展商无法提供适合空运的化工鉴定，请在撤馆重新包装物品时将以上电池等管制物品取出。**
- 由于航空公司现在施行了更加严格的安检规定并针对航空运输中的很多安全敏感物品如电器、电脑、扬声器等要求磁性检验及消磁处理，如发生以上检验及处理我司将按实报实销向展商收取。

### **RE-EXPORT 回运**

The re-export formality will require about 2 weeks prior to the re-export shipment out of China. If the exhibitor needs the goods to be re-exported urgently, please advise representatives of APT Showfreight on-site of your request as applicable.

货物回运前的复出口的海关手续至少需要 2 个星期的时间。如有任何急需回运的展品，请务必事先通知我司，并于展览会开幕前将所有指示和文件交给我司。

### **FUMIGATION RULES IN CHINA 中国对木质包装要求须知**

**ALL CARGOS WITH SOLID WOOD PACKING MATERIAL (WPM) to China (such as wood block cases, lath cases, pallets, frames, drums, axes, chocks, stow-wood, crossties and so on), fumigation must be arranged in the country of origin before sending the cargo to China.**

To ensure the WPM is properly treated either by Heat Treatment (HT) or Methyl Bromide (MB), following information **MUST** be marked or stamped on the outside packing as the below sample:

**WOOD PACKING MATERIALS WITHOUT ACCEPTABLE STAMP OR NOT IN COMPLIANCE WITH THE ABOVE REQUIREMENTS WILL BE DESTROYED.** If the IPPC stamp was unclear/ half-printed/ hidden, the CIQ department will force to destroy the case with penalty before our delivery.

根据中国国家质量监督检验检疫总局的公告，所有含木质包装的入境货物（本公告所称木质包装是指用于承载、包装、铺垫、支撑、加固货物的木质材料，如木板箱、木条箱、木托盘、木框、木桶、木轴、木楔、垫衬木、枕木等），应当由输出国家或地区政府植物检疫机构认可的企业按中国确认的检疫除害处理方法处理。

为保证所有入境货物的木质包装在输出国经过热处理（HT）或溴甲烷（MB）熏蒸，所有木质包装上必须加施政府植物检疫机构批准的 IPPC 专用标识，如图所示。

所有入境货物的木质外包装若无有效的熏蒸标识，或标识不清/不全/被遮挡，包装箱将被中国检验检疫局就地销毁并对参展商处以罚金。

### **HIRE OF LABOUR OR EQUIPMENT ETC 雇佣工人及设备**

If exhibitor requires additional labor or equipment, please contact us for quotation at least 48 hours before show move-in.

如需于非正常工作时段内雇用工人或设备，我司将另行报价。雇用请求请提前 48 小时通知我司。

### **INSURANCE 保险**

It is the responsibility of each exhibitor to arrange Marine (Transport) Insurance covering transport to the exhibition, during the exhibition, till the return of the exhibits to domicile/ exhibits sold locally, including the period the exhibits are handled by APT Showfreight Limited. Our tariff is computed on the basis of volume and weight and has no correlation with the value of exhibits, which means the cost

of insurance cover is not included in our charges. If any exhibition goods were damaged by APT's responsibility without insurance coverage, APT can pay for claim at maximum three times of handling fee for damaged exhibits.

展商需自行投保，保险范围需要涵盖展品从始发地发运到目的地，展会期间保险，直至展品送回到发运地或者展品在当地售卖后的收货点，包括展品在安普特物流公司操作期间的保险。由于我司的报价是根据货物的体积或重量计费的，与货物价值无关，因此不包括保险费用。如展品在运输过程中由于我司过失造成损伤，如无保险，我司将按照行业规定在该受损物品的运输费 3 倍比例以内予以赔付。

### **ADDITIONAL SERVICES 其他服务**

For additional services not listed above, an individual quotation will be given upon receipt of requirements.

如有任何上述未有提及之收费，我司将再另行报价。

### **TERMS OF PAYMENT 支付条款**

**Inward** : Upon presentation of invoice/ prior to delivery to booth.

**Outward** : Upon presentation of invoice/prior to begin re-export.

**All payments must be made without any deduction or deferment on account of any claim, counterclaim or offset.**

Details of our bank account:

**Beneficiary Bank Name:** HSBC Hong Kong

**Beneficiary Bank Code:** 004

**SWIFT Address:** HSBCHKHCHK

**Account Number:** 813-221496-838

**Account Name:** APT SHOWFREIGHT LIMITED

**Bank Address:** NO 1, QUEEN'S ROAD CENTRAL, Hong Kong

(Remitting bank charges are to be borne by the exhibitor)

来程费用 : 提交账单之后，送货上展台之前。

回程费用 : 提交账单之后，货物开始退运之前。

所有费用不得因任何索赔，反索赔或补偿而减除或延期支付。

展商可通过银行汇票或电汇至我公司账号：

**收款行名称：** HSBC Hong Kong

**收款行编号：** 004

**SWIFT 地址：** HSBCHKHCHK

**收款人帐号：** 813-221496-838

**收款人名称：** APT SHOWFREIGHT LIMITED

**银行地址：** NO 1, QUEEN'S ROAD CENTRAL, Hong Kong

(银行汇款手续费用由展商自付)

### **TERMS AND CONDITIONS 公司条款**

APT Showfreight Shanghai Co., Ltd does not take any responsibility for:

- a) Exhibits which are not allowed by the organizer or Chinese Customs to be sold or displayed at the fairground.
- b) Any tax/duty for sold exhibits
- c) Loss of goods whilst on display at the venue

All business is only transacted in accordance with our Standard Trading Conditions. A copy is available upon request.

Use of APT Showfreight Shanghai Co., Ltd's services – be it partly or in full – and any requirement for additional services at any time before, during or after the exhibition express orally and/or in writing and/or by conduct, implies acknowledgement and acceptance of the foregoing.

上海安普特物流有限公司不会负责-

- a) 任何被主办单位或中国海关拒绝于展览会售卖或陈列之展品
- b) 任何展品售卖之税项
- c) 任何于展会期间失窃的展品

所有业务根据我们的“标准贸易条款”执行，全文供索取。

在展览前、期间或展览后，无论全部或部分使用我司的服务，无论以口头、书面或行为方式所提出的额外服务要求，都表示您已清楚并接受上述各项条款。



## **HANDLING TARIFF**

### **A. AIRFREIGHT**

#### **a. INWARD MOVEMENT**

From arrival Beijing Airport to exhibition booth inclusive of removal and temporary storage of empty packing cases (where applicable) at site.

Basic Handling Rate	USD 1.20 per kg based on actual or volumetric weight whichever is the greater, min. 100kg per consignment per exhibitor
Airport THC	USD 0.30 per kg based on actual or volumetric weight whichever is the greater, min. 100kg per consignment per exhibitor
Consignment Service Charge	USD 80.00 per consignment per exhibitor
Temporary/Permanent Import agency Fee	USD 350.00 per consignment per exhibitor
Customs Declaration Fee	USD 150.00 per consignment per exhibitor
Terminal Agency Fee	USD 100.00 per consignment per exhibitor

#### **b. OUTWARD MOVEMENT**

From exhibition booth to on-board the aircraft at Beijing Airport, inclusive of the return of empty packing cases to the exhibition stand, where applicable.

Basic Handling Rate	USD 1.20 per kg based on actual or volumetric weight whichever is the greater, min. 100kg per consignment per exhibitor
Airport THC	USD 0.30 per kg based on actual or volumetric weight whichever is the greater, min. 100kg per consignment per exhibitor
Consignment Service charge	USD 80.00 per consignment per exhibitor
Temporary/Permanent Import agency Fee	USD 380.00 per consignment per exhibitor
Customs Declaration Fee	USD 150.00 per consignment per exhibitor
Terminal Agency Fee	USD 100.00 per consignment per exhibitor

### **B. ON-SITE HANDLING RATES**

The Handling Rate	USD 35.00 per cbm or 1,000 kg whichever is greater, min. 2 cbm
Empty cases storage charge	USD 25.00 per cbm, min. 2 cbm
Labor charge (If request)	USD 80.00 per labor per hour, min. 4 hours

**C. STORAGE AT SHOW SITE / CUSTOMS BONDED WAREHOUSE**

Storage at show site / bonded warehouse where from the date of exhibits arrival, exhibition period, and till departure of the site / bonded warehouse

Airfreight	USD 2.50 per 100kg per day, minimum charge 100kg
Warehouse Handling Fee	USD 0.05 / kg (one time in & out moving) min. USD 25.00 per consignment per exhibitor

**D. QUARANTINE CHARGES**

Under 2 cbm	USD 80.00 per shipment per exhibitor
2 cbm and / or over	USD 150.00 per shipment per exhibitor

\* Quarantine treatment, such as Fumigation, disinfection that may be requested by the Import/Export Quarantine Authority, and the cost will be debited as per outlay.

**E. TRANSPORT OF SOLD EXHIBITS FROM EXHIBITION BOOTH TO BONDED WAREHOUSE**

Handling and Trucking Charge	USD 150.00 per cbm or 1,000 kg whichever is greater Minimum charge 3 cbm per consignment per exhibitor
------------------------------	---

Any charges related with permanent import procedures of sold exhibits will be quoted separately upon request.

**F. TRANSLATION AND DATA ENTRY FEE FOR LIST OF EXHIBITS (LOE)**

Translation Fee	USD 8.00 per page, min. USD 32.00 per consignment per exhibitor
-----------------	--

**G. HAND CARRY ITEMS ARRIVING BEIJING AIRPORT**

Removal & Clearance from airport customs of detained hand carried items	USD 300.00 per shipment per exhibitor
---	---------------------------------------

**H. ATA CARNET HANDLING FEE**

ATA Carnet Handling Fee	USD 30.00 per page, min. USD100.00 per shipment
-------------------------	---

**I. COURIER SHIPMENT DELIVERY FROM APT WAREHOUSE**

Handling charge from APT warehouse to booth	USD 50.00 per cbm per exhibitor, min. 2 cbm
---	---

## (J) ORDER FORM CHECKLIST

Form No.	Order Form	Deadline	Return to	Sent ✓
1a	Stand Contractor Registration/Contractor Passes	13 September, 2024	PICO <a href="http://ordering.picoies.cn/COTTM.aspx">http://ordering.picoies.cn/COTTM.aspx</a>	
1b	Insurance (Raw Space Only)			
2a&2b	Risk list			
2c&2d	Better stands check list (Raw Space Only)			
3a	Stand Fittings Location (Shell Scheme Only)			
4	Furniture Rental			
5	Electrical Supply			

# Form-1a Stand Contractor Registration/Contractor Passes/ Insurance (For Raw Space Only)

Deadline: **13 September 2024**

Exhibitors are reminded that apart from electrical work, they are free to appoint a **contractor** of their choice to design, embellish or build their stands. However, in the interests of security **all contractors are required to register with the Organizers before arriving on site, by completing this form and Form 2a (Safety Commitment Of The Erection Contractor) and 3b (Risk Assessment).**

All design proposals must be approved by the Organizers and should conform with all statutory requirements.

Drawings to scale must be submitted to PICO online system before **13 September 2024** and must show the plan and elevation of the stand and its fittings, state materials used, describe any moving exhibits or displays and give details of measurements, weights and loadings of all exhibits.

**\*\*\*\*\*Raw Space Stands maximum height cannot exceed 4 m. \*\*\*\*\***

Raw Space stands are "Space only". No stand fittings, carpeting, electricity or furniture. All electricity orders must be ordered through the Official Stand Contractor, PICO. Any order received by **PICO** after **13 September 2024** is subject to a **30%** late surcharge, while **50%** surcharge will be levied for onsite orders.

Shell Stands with modifications must also order electricity where necessary. Please note that the 10amp/220V single phase socket provided in the Shell Stand Shell is NOT FOR any kind of lighting connections. Any additional lighting must order lighting connections by returning **Form 7a**. Contractors for Shell Stand modifications must contact **PICO** directly to advise whether stand facilities included in the package will be removed/retained. Any relocations/removal of shell scheme facilities, including carpet, panels, furniture, etc. will be charged onsite.

- ◆ Failure to provide the above information will result in additional charges being levied by the Official Stand Contractor/Exhibition Centre and for safety reasons, may result in the cancellation of your stand.
- ◆ Please refer to "Stand Construction and Management" and "Form 3a-b - Risk Assessment (For raw space only)" for construction and contractor registration details. Nevertheless, it is important that you have insurance coverage in place and also pay a deposit for damage/and/or garbage removal costs (see next page).

Please tick  where appropriate:

- We will appoint an outside contractor to build our **Raw Space** stand, as detailed below.
- Our company will act as an outside contractor to build our own **Raw Space** stand, as completed below.
- We will appoint an outside contractor to modify our **Shell Stand** as detailed below. We understand that our appointed outside contractor is required to contact the Official Stand Contractor (**PICO**) and advise them the items for the shell stand package to be retained/ removed. \*
- Our company will act as an outside contractor to modify our own **Shell Stand** during the move in/out period, as completed below. We understand that we are required to contact the Official Stand Contractor (**PICO**) and advise them the items from the shell stand package to be retained/ removed.

Note: Exhibitors who have booked a standard shell stand are not required to return this form, unless the shell stand is being modified by any outside stand contractors or by themselves.

Please complete the front page and pass to your contractor to complete the next page for application to be made. The appointed stand contractor responsible for the construction of our stand is:

Contractor Name: \_\_\_\_\_ Mobile Phone: \_\_\_\_\_

Tel: \_\_\_\_\_ Fax: \_\_\_\_\_ Email: \_\_\_\_\_

<p><b>Authorized by:</b>                  Exhibiting Company: ..... Stand No:.....                  Contact:.....                  Tell: E-mail:.....                  Signature: ..... Date:.....</p>	<p><b>Please submit to Pico IES Group (China) Co Ltd via the following website:</b>   <a href="http://ordering.picoies.cn/COTTM.aspx">http://ordering.picoies.cn/COTTM.aspx</a>   <b>Please contact Ms. Susan Zhang / Ms. Serena Li (susan.zhang@pico.com / serena.li@pico.com) if you encounter any difficulties in using the system.</b></p>
--	--

# Form-1b STAND CONTRACTOR REGISTRATION / CONTRACTOR PASSES / INSURANCE (FOR RAW SPACE ONLY)

Deadline: **13 September 2024**

---

## 1. REGISTRATION & DAMAGE DEPOSIT PAYMENT

**This section should be completed by the contractor** as appointed by the individual exhibitor, (or if an individual exhibitor building up their own stand, they are considered as an outside contractor during the move-in/out period). The Damage Deposit is equivalent to **RMB 10000 (<36 m<sup>2</sup>)** , **RMB 15000 (36 m<sup>2</sup>-72 m<sup>2</sup>)** , **RMB 20000 (72 m<sup>2</sup>)** . The deposit will be refunded by **PICO** after the exhibition, subject to the clearance of the site by the contractors and no damage being recorded by Exhibition Centre management. **PICO** charges all contractors badge fee (**RMB50 each**).

A/C Name: PICO IES GROUP (CHINA) CO., LTD

USD A/C No.: 409474014301

Bank Name: STANDARD CHARTERED BANK SHANGHAI BRANCH

Address: 26th Floor Standard Chartered Tower, 201 Century Avenue Pudong, Shanghai 200120, China

Swift Code: SCBL CNSXSHA

It is the individual stand contractor's responsibility to remove all packing and waste materials from the Centre during both move-in and move-out. Garbage & waste materials from decoration work must not be discarded into the aisles & must be cleared daily. All material used must be removed during move-out and this must be done safely (no pushing over of high pieces of stand, no smashing of glass panels etc). Failure to comply will result in the contractor deposit being totally forfeited. (The Organizers will take photos as a record).

**Damage Deposits should be paid (IN CASH) on-site to the Official Stand Contractor, PICO.** For payment details, please contact: PICO. Please note that your contractor must be approved by The Chinese Fairs/Tax Authorities and will be liable for any taxes or levies which may be applied.

## 2. CONTRACTOR INSURANCE COVERAGE

Individual Stand Contractors are required to take out and maintain Exhibition liability insurance in respect of the Individual Stand Contractor's liability for death or injury to any person, or loss or damage to property arising out of the performance of the Services in a sum not less than RMB 15 million for any single claim, unlimited in aggregate. In addition, an Individual Stand Contractor shall take out and maintain valid and adequate insurance cover against theft, fire, damage to property, accidents, natural calamities, acts of God and such other risks normally insured against by a reasonable person in the position of the Individual Stand Contractor, or as **Informa Markets** may require, in connection with, inter alia, the Individual Stand Contractor's property (including all equipment, fittings, furniture, materials and other facilities used or provided by the Individual Stand Contractor in the performance of the Services) and the performance of the Services. The insurance shall be maintained in force during the Move-in Period, Exhibition Period and Move-out Period.

Each Individual Stand Contractor **MUST HAVE** valid and adequate insurance cover of not less than **RMB 15 million** against public liability. Individual Stand Contractors are required to present the certificate to the Organizers prior move-in. The Organizers will reject work and refuse entry to Stand Contractors that fail to do so.

## 3. HALL MANAGEMENT FEE

**PICO** charges all contractors a HALL MANAGEMENT FEE (**RMB 55/sqm**) which is non-refundable. Please note the Exhibition Centre reserves the right to refuse a contractor access, should the management fee not be paid before the move-in period.

Contractors must provide badges to all personnel engaged in the construction of stands during the move-in and move-out period. All outside contractors are requested to order badges directly from <https://szhz.lzshanghai.com>

All the contractor workers should do the real-name authentication before **13 September 2024**. More information about the handing procedures you can visit: <https://szhz.lzshanghai.com>

The appointed stand contractor responsible for the construction of the stand:

Contractor Name: \_\_\_\_\_

Contact Person: \_\_\_\_\_ Mobile Phone: \_\_\_\_\_

Tel: \_\_\_\_\_ Fax: \_\_\_\_\_ E-mail: \_\_\_\_\_

Address: \_\_\_\_\_

# Form-1c STAND CONTRACTOR REGISTRATION / CONTRACTOR PASSES / INSURANCE (FOR RAW SPACE ONLY)

Deadline: **13 September 2024**

## NOTICE FOR RAW SPACE INSURANCE

Items	Company Name	Contact Person	Contact Details
Provide Exhibition Liability Insurance for Raw Space Stand Construction	上海一鸣优信保险代理有限公司	Specialist Ms. Nancy Lin Ms. Yolanda Duan	(86) 1801 6358 139 (86) 1379 5447 441 (86) 1302 1092 086

To cover the liability risk to any exhibitor and its respective appointed contractor arising from the use or construction of each raw space during move-in days, each raw space exhibitor or its contractor is requested to purchase insurance in accordance with the requirements before getting the admission of processing its application such as getting booth design approval, ordering electricity and settling hall management fees etc.

1. All raw space contractors, exhibitors should be the insured under such liability insurance policy.
- 2.
3. The liability insurance policy of each raw space exhibitor should cover the following parts:  
The indemnity limit for any one accident and in aggregate for each booth should be no less than RMB15,000,000.
  - 2.1 Loss of buildings in the exhibition venue, fixed equipment, the ground and the foundation in the exhibition area. Aggregate compensation limit shall be no less than RMB1,000,000;
  - 2.2 Onsite employees' bodily injuries compensation, including but not limited to pension and medical expenses. Aggregate compensation limit shall be no less than RMB2, 000,000; and the maximum compensation per person shall be no less than RMB400,000;
  - 2.3 Bodily injury of a third party onsite, resulting in pensions, medical expenses and other related expenses. Aggregate compensation limit shall be no less than RMB 2,000,000 and the maximum compensation per person shall be no less than RMB500,000;
  - 2.4 The premium of each policy is RMB500.

3, 上海一鸣优信保险代理有限公司 is the officially appointed insurance intermediary and Generali is the insurer. Pls. login the website <https://ubm.general-china.cn> or Scan WeChat QR Code



to apply the insurance before **13 September 2024** to ensure the contractor can complete the related procedure before move-in.

Should you have any questions on insurance related, pls. contact Ms. Kefu or Ms. Nancy Lin or Ms. Yolanda Duan for enquiry. The contact details are as below.

Specialist  
M: 1801 6358 139  
E: zhanhuikefu2022@163.com

Ms. Nancy Lin  
M: 1379 5447 441  
E: nancy.lin@clema-rs.com

Ms. Yolanda Duan  
M: 1302 1092 086  
E: yolanda.duan@clema-rs.com

## Form-2a Risk Assessment Template

List hazards which you will expect to encounter on-site. Use the following examples as a guide:

<b>Hazards</b>	<ul style="list-style-type: none"> <li>• Slipping/Tripping hazards (e.g. poorly maintained floors or stairs)</li> <li>• Fire (e.g. from flammable materials)</li> <li>• Chemicals &amp; Hazardous substances (e.g. cleaning fluids)</li> <li>• Moving parts of machinery (e.g. blades)</li> <li>• Working at height above 2.5m (e.g. platforms, tower scaffolds, etc)</li> <li>• Vehicles</li> <li>• Electricity (e.g. wiring)</li> <li>• Fumes (e.g. machinery)</li> <li>• Manual Handling</li> <li>• Noise</li> <li>• Temperatures</li> <li>• Water Features</li> </ul>
<b>Who is affected?</b>	<p>List of groups of people who could be harmed and how:</p> <ul style="list-style-type: none"> <li>• Maintenance staff</li> <li>• Contractors</li> <li>• People sharing your stand/space</li> <li>• Cleaners</li> <li>• Visitors</li> <li>• Pregnant women</li> <li>• Staff / visitors with disabilities</li> <li>• Inexperienced and new staff</li> <li>• Foreign staff/visitors</li> <li>• Overtime workers</li> <li>• Organisers</li> <li>• Venue staff</li> </ul>
<b>Level of risk</b>	<p>Indicate the level of risk to who or what?</p> <ul style="list-style-type: none"> <li>• High</li> <li>• Medium</li> <li>• Low</li> </ul>
<b>Precautions / Action</b>	<p>After evaluating the risks, now indicate what precautions/actions you have already taken or intend to carry out:</p> <p>For example:</p> <ul style="list-style-type: none"> <li>• Are all employees adequately trained or informed?</li> <li>• Erect warning signs where there is overhead work being carried out</li> <li>• Ensure waste is removed promptly</li> <li>• Ensure machinery, ladders etc. are tested before bringing on to site</li> </ul> <p>Do the precautions:</p> <ul style="list-style-type: none"> <li>• Adhere to rules/Organisers manual?</li> <li>• Have local authority approval if necessary?</li> <li>• Comply with industry standards?</li> </ul>
<b>Further Action</b>	<p>Can any of the risks be reduced further? If applicable, list what further precautions/actions you can take?</p>

# Form-2b Risk Assessment

Deadline: **13 September 2024**

<b>Hazard</b>	
<b>Who is affected?</b>	
<b>Level of risk</b>	
<b>Precautions / Action</b>	
<b>Further Action</b>	

Assessment by (Person from Contracting Company): \_\_\_\_\_  
Title / Contracting Company Name: \_\_\_\_\_  
Risk Assessment For (Exhibiting Company): \_\_\_\_\_  
Date: \_\_\_\_\_



## Form-2c STANDS CHECK LIST (FOR RAW SPACE ONLY)

Deadline: **13 September 2024**

"Better Stands" is a new concept of exhibition environmental protection passed by Informa Markets in recent years, which aim to move away from the use of disposable exhibition stands, improving a ease, quality, safety and sustainability of the exhibitor experience at our events. We would like our exhibitors/contractors to join us in moving towards the future of exhibiting. Please review the construction materials of your stand and register in the form below.

One single stand can create around 4 tons of waste. They also take longer to build, are riskier to plan and can contain a lot of hidden costs. We believe that by moving away from the use of disposable exhibition stands we will improve the ease, quality, safety and sustainability of the exhibitor experience at our events. We would like our exhibitors/contractors to join us in moving towards the future of exhibiting.

### **Do you know what happens to your stand?**

#### **❓ What is a disposable / single-use stand?**

Space only / raw space stands made to be used only once which are usually constructed from raw materials at the venue during build up. The stands are demolished and disposed of after the event and the **stand materials are not reused or recyclable.**

#### **❓ What is a reuseable stand?**

A reusable / non-disposable stand is constructed using materials designed to be used multiple times. There are almost endless variations of multiple use stands to suit every size and desired appearance.

#### **❓ Benefits to building a non-disposable stand**

- Faster, cleaner and safer build with a more reliable timeline – no stress!
- Reduced costs due to a lower waste bill and fewer labor hours
- Higher quality look and feel for your stand
- Demonstrates your company's commitment to sustainability with a lower environmental

impact

#### **❓ What are the new regulations?**

what we encourage you to do?	We do not encourage
All core structure elements, i.e. walls, floor platform, ceilings, furniture, and etc, should be constructed with reusable materials, e.g. frame & fabric, reusable panels etc.	The use of other raw materials to construct the core structure elements, i.e. walls, floors and ceilings, that are <u>not planned</u> to be reused or recycled after use.
The stand structure should be prefabricated and ready to assemble onsite.	Building from scratch onsite of any stand core elements.
Final adjustment to prefabricated pieces for fitting purposes is allowed.	The use of non-recyclable carpet, PVC vinyl flooring.
Final coat of acceptable TVOC paints for repair purposes only.	
The use of LED lighting.	
Floor flats and system floors should be cut to size before coming onsite and be recyclable and/or reusable.	
The use of recyclable / recycled / 2 <sup>nd</sup> hand carpet, other eco vinyl flooring / coverings.	

\* A prefabricated stand is one which arrives at the event in component pieces ready to put / assemble together, reducing the need for construction work onsite. At the end of the event the stand is dismantled back into pieces and stored for reuse at another event.

You must make your appointed stand contractor aware of the regulations and brief them to design and build a sustainable, multiple use stand. For more information, please contact our Sales Team or Operations team

We would also like to encourage you to join our sustainability efforts by completing the 8-points checklist enclosed in this document.

Pre-show	For your travel and transport, choose the most sustainable option possible for your journey to and from the event. Consolidate your shipments and use logistic companies that have sustainability credentials
	When purchasing promotional items, consider the amount you order, the environmental credentials of the materials they are made from, as well as whether they are useful giveaways that will be used long after the event is over
	Help to support the sustainability of the local area by using local suppliers and considering the sustainability credentials of the hotels you book
	Inspire the sustainable development of your industry by promoting your company's and your products' sustainability credentials
Show Period	Select energy efficient, LED lighting and other equipment for your stand and be sure to power down your equipment at the end of the day
	Reduce paper handouts by going digital and source recycled, sustainably certified paper options where printing is needed. Eg, FSC or recycled paper
	Ensure you and your contractor are aware of and compliant with all health, safety and security requirements
	Get involved with the numerous initiatives and conversations throughout the event which aim to help facilitate and inspire the sustainable development of your industry

## Form-2d BETTER STANDS CHECK LIST (FOR RAW SPACE ONLY)

Deadline: **13 September 2024**

Please review the construction materials of your stand and register in the form below.

<b>* Please fill in the following items to list whether your stand construction includes reusable / non-disposable materials</b>		
Stand structure and walls (select all that apply) ( structure or framework of the stand, walls, panels for meeting rooms, backdrop, none )	e.g. Structure or framework of the stand, walls, panels for meeting rooms, backdrop, none	Percentage of reusable / non-disposable materials (0%、0-50%、60-70%、80%、90%、100%)
Floor Platform	e.g Structure and flooring (excluding carpet),none	
Furniture and Equipment ( select all that apply ) ( Showcases, furniture, LED walls, TV, AV equipment and etc, none )	e.g. Showcases, furniture, LED walls, TV, AV equipment and etc, none	
Lightings	e.g.All kinds of lightings in the stand and showcases, none	
Ceiling	e.g. Ceiling structure for lightings or for stand support, none	
Overhead signage or branding	e.g.Fascia, company logo on top of the stand structure	
Rigging structure (*Only Hall 1)	e.g.Hanging structure for stand branding or support, none	
Build-in or detachable display facilities	e.g. lightboxes, shelves, doors and etc, none	
Decorative items (reusable / recyclable)	e.g.Laminate stickers, fabric, paper board, foamboard, posters, standing banners and etc, none	
Carpet (reusable / recyclable)	e.g.Carpet, other floor coverings.	

<p><b>Authorized by:</b></p> <p>Exhibiting Company: ..... Stand No: .....</p> <p>Contact: ..... Position: .....</p> <p>Tel: ..... Fax: ..... Email: .....</p> <p>Signature: ..... Date: .....</p>	<p>Please submit to Pico IES Group (China) Co Ltd via the following website:</p> <p><a href="http://ordering.picoies.cn/COTTM.aspx">http://ordering.picoies.cn/COTTM.aspx</a></p> <p>Please contact Ms. Susan Zhang / Ms. Serena Li (susan.zhang@pico.com / serena.li@pico.com) if you encounter any difficulties in using the system.</p>
---	--

# Form-3a STAND FITTINGS LOCATION (SHELL SCHEME ONLY)

Deadline: **13 September 2024**

Exhibitors are requested to indicate on the plan below the position of all electrics, wall fittings and shelving, etc.

## PERSPECTIVE VIEW

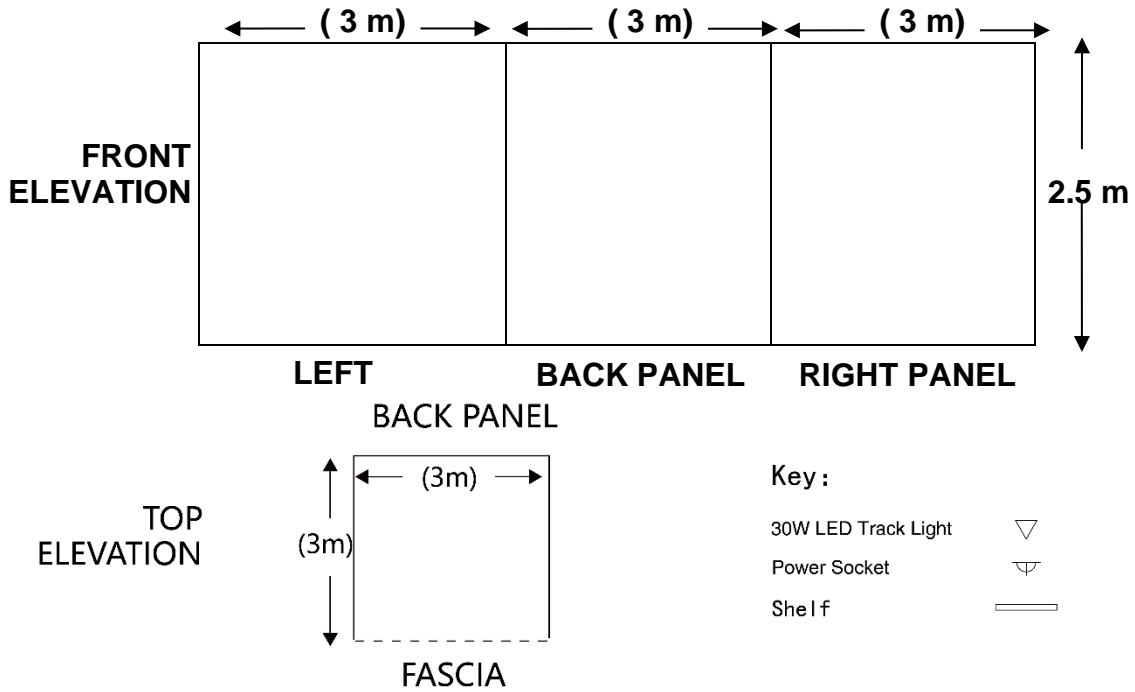

- ◆ Please read “**Conditions of Hire**”
- ◆ If the location plan of any ordered item is not submitted, it will be placed according to a standard layout plan and additional orders will be placed at the discretion of the Official Stand Contractor. Any relocation on site is subject to service charge equivalent to 50% of the unit price.

<p><b>Authorized by:</b></p> <p>Exhibiting Company: ..... Stand No: .....</p> <p>Contact: ..... Position: .....</p> <p>Tel: ..... Fax: ..... Email: .....</p> <p>Signature: ..... Date: .....</p>	<p><b>Please submit to Pico IES Group (China) Co Ltd via the following website:</b></p> <p><a href="http://ordering.picoies.cn/COTTM.aspx">http://ordering.picoies.cn/COTTM.aspx</a></p> <p><b>Please contact Ms. Susan Zhang / Ms. Serena Li (susan.zhang@pico.com / serena.li@pico.com) if you encounter any difficulties in using the system.</b></p>
---	--

**Form-3b STAND POSTERS PRINTING (SHELL SCHEME ONLY)**

Deadline: **13 September 2024**

---

If you need the printing service, please contact the official contractor PICO.

Contact details:  
Ms. Susan Zhang / Ms. Serena Li  
Tel: +86 21 6010 8786/ 6010 8774  
E-mail: susan.zhang@pico.com/ serena.li@pico.com

The quotation is as follows:

<b>Description</b>	<b>Price (RMB)</b>
Injekt printing	RMB180/sqm
Injekt printing with foamboard	RMB220/sqm

## CONDITIONS OF HIRE:

1. All items ordered are on rental basis and Exhibitors must make good any damage or loss incurred.
2. Exhibitors with very sensitive equipment are advised to bring their own stabilizer to cater for voltage fluctuations.
3. Any power points and sockets are for electricity supply for exhibits only, exhibitors are not permitted to fix their own spotlights or fluorescent lights. Special lighting supplied by exhibitors can be handed over to PICO for installation at a nominal price.
4. Where it is not otherwise stated, the prices are for the duration of the exhibition days, and subject to change without prior notice.
5. Exhibitors are asked to return the order form including additional furniture and electrical equipment

ON OR BEFORE THE DEADLINE: **13 September 2024**

### SURCHARGE IS LEVIED ON:

- a. LATE ORDERS- Any order received after the deadline is subject to a 30% surcharge.
- b. ON-SITE ORDERS-Any order received on-site is subject to a 50% surcharge and availability at the point of ordering.

Exhibitors will receive an invoice from the Official Stand Contractor for sales confirmation if order has placed. No reply from exhibitor will be assumed as no additional request.

1. Stand Fittings Layout
2. All exhibitors are requested to submit the location plan indicating the position of lighting fixtures, sockets, wall panels and shelves (with height), etc. Include both the standard provision and any extra items you have ordered

BEFORE THE DEADLINE: **13 September 2024.**

If the location plan is not submitted, orders will be placed according to the standard shell scheme stand layout plan and additional orders will be placed at the discretion of the Official Stand Contractor. **ANY RELOCATION ON SITE IS SUBJECT TO SERVICE CHARGE.**

3. Orders without remittance will not be accepted.

### PAYMENT DETAILS

All orders must be accompanied with full payment either by:

Bank draft payable to: A/C Name: PICO IES GROUP (CHINA) CO., LTD

USD A/C No.: 409474014301

Bank Name: STANDARD CHARTERED BANK SHANGHAI BRANCH

Address: 26th Floor Standard Chartered Tower, 201 Century Avenue Pudong, Shanghai 200120, China

Swift Code: SCBLCNSXSHA

Please fax the bank-in slip or T/T statement with company name & stand number to PICO (payment from overseas) as a confirmation of the payment.

## Form-4 FURNITURE RENTAL

Deadline: **13 SEPTEMBER 2024**

Description	Price RMB	NO.	Remark
Folding chair	50	EC-08	450*400*455mmH
Black leather chair	140	CC-05	560*550*820mmH
Bar stool	200	EC-14b	360*400*760~860mmH
Sofa(single)	560	AU-02	800*730*790mmH
Sofa(two-seat)	840	AU-03	1300*730*790mmH
Consultation desk	170	PF-01	1030*535*750mmH
Square table	170	PF-12	650*650*750mmH
Long square table	420	ES-12	1800*600*750mmH
Round table	170	ET-06	800*750mmH
TV stand	210	PF-13	740*535*1000H
Bar table	280	ET-10	600*1100mmH
Lock cabinet	210	PF-03	1030*535*750mmH
Transparent glass showcase (low)	480	PF-02	1030*535*1000mmH
Transparent glass showcase (high)	780	PF-04	1030*535*2000mmH
Showcase	210	PF-07	535*535*750mmH
Coaming	140		1000*2500mmH
Door with lock	480	ED-01	950*1910mmH
Folding door	420	ED-02	950*2000mmH
Storage rack	480		
Hanger	280	ES-08	1200*500*1600mmH
Flat laminate	85	FS-01	1000*300mm
Inclined laminate	85	SS-01	1000*300mm
A4 data frame	145	CH-04	270*250*1200mmH
Bin	15	EW-01	
LED long arm lamp	150	SL-006	
Power socket	150		
Power socket (high-power)	360		1000 (maximum)
Daylight lamp	150	SL-001	
LED track light	210		
42" LCD	2100		
Water dispenser	480	EE-04	300*300*960mmH With 3 buckets water
Fridge	1050	EE-03	90L
1meter blocker	110	ES-11	1000~1200*900mmH

\*Please see terms and conditions of hire.

\*Any relocation of wall fittings on site is subject to service charge equivalent to 20% of the above unit price.

## Form-5 ELECTRICAL SUPPLY

Deadline: **13 September 2024**

Electricity is supplied by the Exhibition Centre only through the Organiser. For this purpose, PICO has the authority to act as agent of the Organiser. No other contractors will be permitted to undertake electrical work in the Centre.

Code	Description	Unit Price (RMB)	No. Required	Total Amount
*	15Amp/380V Three Phase	3540		
*	30Amp/380V Three Phase	5160		
*	60Amp/380V Three Phase	6960		
*	100Amp/380V Three Phase	9720		
*	10A/220V Electricity for move-in	1660		
Total:				

\*Any relocation on site is subject to service charge equivalent to 50% of the above unit price.

<p><b>Authorized by:</b></p> <p>Exhibiting Company: ..... Stand No: .....</p> <p>Contact: ..... Position: .....</p> <p>Tel: ..... Fax: ..... Email: .....</p> <p>Signature: ..... Date: .....</p>	<p><b>Please submit your orders to Pico IES Group (China) Co Ltd via the following website:</b></p> <p><a href="http://ordering.picoies.cn/COTTM.aspx">http://ordering.picoies.cn/COTTM.aspx</a></p> <p><b>Please contact Ms. Susan Zhang / Ms. Serena Li (susan.zhang@pico.com / serena.li@pico.com) if you encounter any difficulties in using the system.</b></p>
---	--



# Furniture rental Diagram



Furniture & Fittings Catalogue 家具安装目录



**CC-05**  
黑色皮扶手椅  
Black leather arm chair  
560\*550\*820H



**CC-07**  
办公椅(黑)  
Office chair (black)  
500\*560\*870-970H



**CC-08**  
木纹椅  
Meeting chair  
560\*500\*920H



**CC-09**  
木纹椅(白)  
Meeting chair (white)  
420\*500\*930H



**CC-10**  
贝壳椅(白)  
Meeting chair (white)  
600\*600\*780H



**CC-11a**  
葫芦椅(红)  
Meeting chair (red)  
480\*550\*800H



**CC-11b**  
葫芦椅(白)  
Meeting chair (white)  
480\*550\*800H



**EC-08**  
折椅  
Folding chair  
450\*400\*455H



**EC-09**  
铝休闲椅  
Aluminium chair  
460\*550\*800H



**EC-11**  
洽谈椅  
Conference chair  
580\*600\*900H



**EC-14a**  
L型吧椅(黑)  
Bar stool (black)  
360\*400\*760-860H



**EC-14b**  
L型吧椅(白)  
Bar stool (white)  
360\*400\*760-860H



**EC-14c**  
L型吧椅(红)  
Bar stool (red)  
360\*400\*760-860H



**EC-15**  
行政椅  
Executive chair  
600\*560\*900-1000H



**AU-02**  
单人沙发  
Sofa  
800\*730\*790H



**AU-03**  
双人沙发  
Sofa  
1300\*730\*790H

 Furniture & Fittings Catalogue 家具安装目录



**AU-04**  
三人沙发  
Sofa  
1800\*730\*790H



**AU-07a**  
单人休闲沙发(黑)  
Sofa (black)  
600\*570\*730H



**AU-07b**  
单人休闲沙发(红)  
Sofa (red)  
600\*570\*730H



**ET-03**  
玻璃茶几  
Long glass coffee table  
1100\*550\*450H



**ET-04**  
玻璃茶几  
Glass coffee table  
550\*550\*450H



**ET-05**  
玻璃圆桌  
Glass round table  
800\*750H



**ET-06**  
白圆桌  
Round table  
800\*750H



**ET-07**  
木纹圆桌  
Round table  
800\*750H



**ET-08**  
黑木纹圆桌  
Round table  
800\*750H



**ET-10**  
木纹吧台  
Bar table  
600\*1100H



**ET-11**  
黑木纹吧台  
Bar table  
600\*1100H



**ET-19**  
会议桌  
Meeting table  
1400\*700\*750H



**ET-20**  
会议桌  
Meeting table  
1400\*700\*750H



**PF-01**  
问询台  
Info counter  
1030\*535\*750H



**PF-02**  
低玻璃展示柜  
Low glass showcase  
1030\*535\*1000H



**PF-03**  
锁柜  
Lockable cupboard  
1030\*535\*750H



**PF-04**  
高玻璃展示柜  
Tall glass showcase  
1030\*535\*2000H



**PF-07/PF-08**  
展示柜  
Tall/Low display cube  
535\*535\*750H/535\*535\*500H



**PF-12**  
方桌  
Square table  
650\*650\*750H



**FS-01/SS-01**  
斜/平层板  
Sloped/Flat shelf  
1000\*300



**ED-01**  
锁门  
Lockable door  
950\*1910H

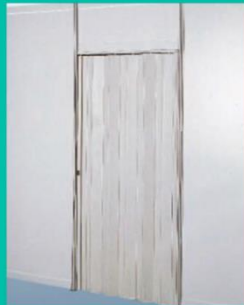

**ED-02**  
折门  
Folding door  
950\*2000H



**CH-01**  
A4资料盒  
A4 catalogue holder (acrylic)  
235\*55\*280H



**CH-02**  
1米信箱  
Catalogue holder (metal)  
970\*50\*280H



**CH-03**  
立式资料架  
Magazine holder  
380\*1500H



**CH-04**  
立式资料架  
Magazine holder  
270\*250\*1200H



**CH-06**  
立式资料架  
Magazine holder  
270\*250\*1200H



**ES-06**  
画架  
Easel  
1500H



**ES-07**  
立式衣架  
Coat hanger  
320\*1700H



**ES-08**  
轮式衣架  
Wheeled coat hanger  
1200\*500\*1600H



**ES-09**  
R8衣架  
R8 coat hanger



**ES-11**  
拉带围栏  
Belt barricade  
1000-1200\*900H



Furniture & Fittings Catalogue 家具安装目录



**ES-12**  
长桌  
Long table w/ apron  
1800\*600\*750H



**SL-001**  
40W日光灯  
40W fluorescent tube



**SL-006**  
10W LED长臂射灯  
10W LED longarm spotlight



**SL-023**  
70W 镭灯  
70W HQI floodlight



**SL-024**  
150W镭灯  
150W HQI floodlight

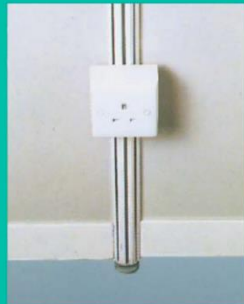

插座  
Power socket



**EW-01**  
废纸篓  
Wastepaper basket



**EE-02**  
90L冰箱  
90L refrigerator  
550\*550\*860H



**EE-03**  
140L冰箱  
140L refrigerator  
550\*550\*1350H



**EE-04**  
立式饮水机  
Water dispenser  
300\*300\*960H



**EE-05**  
蒸馏咖啡机  
Distilled coffee maker  
140\*280\*280H



**EE-06**  
磨豆咖啡机  
Coffee machine  
300\*400\*400H



42英寸等离子电视机  
42" plasma TV



盆栽植物  
Potted plant

## Form 6 - INTERPRETER SERVICE

Return To: COTTM Organiser

Company:

Email: sarah.hu@informa.com

Stand No.:

Contact person: Sarah Hu

DEADLINE DATE: 22<sup>nd</sup> September, 2024

*Note: Add 30% to all orders received after deadline. Add 50% to all orders on site. Exhibitors who order on-site must make payment on site in cash. No credit cards will be accepted.*

Item	Dates Required	Type of Interpreter	Unit Price/Day	No. of Interpreters	Remarks
Stand Accompanying Translation Services		Chinese ↔ English	USD260	1	Onsite interpretation at the exhibition stand
		Chinese ↔ English	USD350		Consecutive interpretation for business negotiations
Translation and Translation Services		Chinese → English	USD50/thousand words		
		English → Chinese	USD40/thousand words		
<b>Wire Transfer Charges (Required)</b>			<b>USD20</b>		
<b>Total Cost</b>			<b>USD</b>		

\*Please contact us should you require interpretation for other languages. Relevant charges apply.

<b>Authorized By:</b>	
Name:	Title:
Company:	
Address:	
Tel:	Email: